

## General Description

The LTA321L / LTA323L / LTA2904L series amplifiers are the industry-standard operational amplifiers which include different channels of high-voltage(36V) op-amps. These devices provide outstanding value for cost-sensitive applications, with features including low offset, common-mode input range to ground. These series standard op-amps could simplify circuit design with enhanced features, such as unitygain stability and lower quiescent current of 250 $\mu$ A per amplifier (typical). The single of LTA321L and LTA323L is offered in both SOT23-5L package, the dual of LTA2904L is offered in SOIC-8L and MSOP-8L packages.

## Features and Benefits

- Wide Supply:  $\pm 1.5$  V to  $\pm 18$  V, 3.0 V to 36 V
- Extended Temperature Range:  $-40^{\circ}\text{C}$  ~  $+125^{\circ}\text{C}$
- Offset Voltage:  $\pm 2$  mV (typical)
- Offset Voltage Temperature Drift:  $7\mu\text{V}/^{\circ}\text{C}$
- Input Common-Mode Voltage Range Includes Ground
- Large Voltage Gain: 85 dB (typical)
- Gain Bandwidth: 0.5 MHz
- Slew Rate: 0.2V/ $\mu$ s
- Quiescent Current: 275  $\mu$ A/ch (typical)
- Large Output Voltage Swing: 0 V to  $V_{\text{CC}} - 2$  V

## Applications

- Merchant network and server power supply units
- Multi-functional printers
- Power supplies and mobile chargers
- Motor control: AC induction, BDC, BLDC and stepper Motor ,etc
- Indoor and outdoor air conditioners
- Washers, dryers, and refrigerators
- AC inverters, string inverters, central inverters
- Electronic point-of-sale systems

Table of Content

General Description .....	1
Features and Benefits .....	1
Applications .....	1
Table of Content .....	2
Ordering Information <sup>(1)</sup> .....	3
Pin Configuration (Top View) .....	4
Limiting Value .....	6
ESD Ratings .....	6
Thermal Information .....	6
Electrical Characteristics .....	7
Typical Characteristics .....	8
Tape and Reel Information .....	10
Package Outlines .....	11
Important Notice .....	15

### Ordering Information<sup>(1)</sup>

Part Number	Package Type	Package Size	Package Quantity	ECO Class <sup>(2)</sup>	Mark Code <sup>(3)</sup>
LTA321LXT5/R6	SOT23-5L	2.92 mm * 1.60 mm	Tape and Reel, 3 000	Green (RoHS & no Sb/Br)	X321
LTA323LXT5/R6	SOT23-5L	2.92 mm * 1.60 mm	Tape and Reel, 3 000	Green (RoHS & no Sb/Br)	X323
LTA2904LXS8/R8	SOIC-8L	4.90 mm * 3.92 mm	Tape and Reel, 4 000	Green (RoHS & no Sb/Br)	X2904
LTA2904LXV8/R6	MSOP-8L	3.00 mm * 3.00 mm	Tape and Reel, 3 000	Green (RoHS & no Sb/Br)	X2904
LTA2904LXT8/R6	TSSOP-8L	4.40 mm * 3.00 mm	Tape and Reel, 3 000	Green (RoHS & no Sb/Br)	X2904

(1) Please contact to your Linearin representative for the latest availability information and product content details.

(2) Eco Class - The planned eco-friendly classification: Pb-Free (RoHS) or Green (RoHS & Halogen Free).

(3) There may be multiple device markings, or additional marking, which relates to the logo, the lot trace code information, or the environmental category on the device.

### Pin Configuration (Top View)

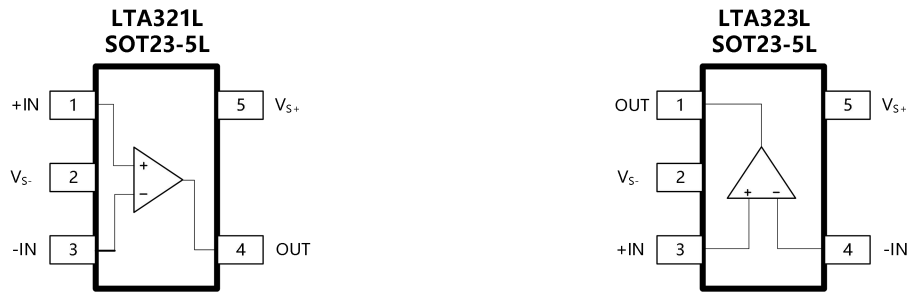

PIN Name	LTA321L	LTA323L	Description
-IN	3	4	Inverting input of the amplifier. The voltage range is from $V_{S-}$ to $V_{S+} - 2.0V$ .
+IN	1	3	Non-inverting input of the amplifier. This pin has the same voltage range as -IN.
OUT	4	1	Amplifier Output
$V_{S-}$	2	2	Negative power supply. It is normally tied to ground. It can also be tied to a voltage other than ground as long as the voltage between $V_{S+}$ and $V_{S-}$ is from 3.0V to 36V.
$V_{S+}$	5	5	Positive power supply. The voltage is from 3.0V to 36V. Split supplies are possible as long as the voltage between $V_{S+}$ and $V_{S-}$ is from 3.0V to 36V.

### Pin Configuration (Top View)

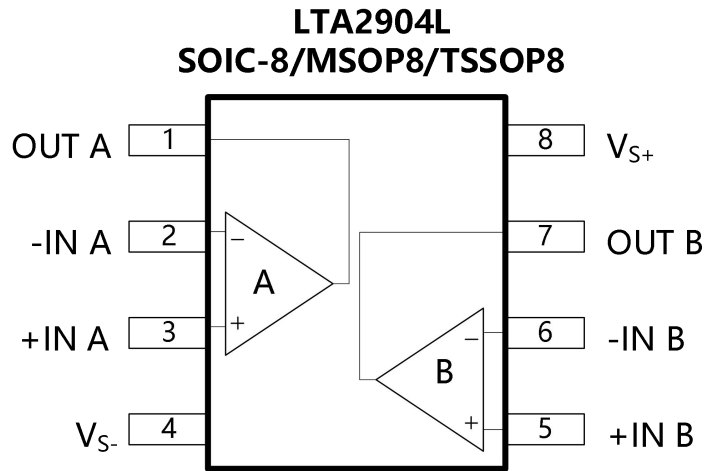

PIN Name	LTA2904L	Description
-IN A	2	Inverting input A of the amplifier. The voltage range is from $V_{S-}$ to $V_{S+} - 2.0V$ .
+IN A	3	Non-inverting input A of the amplifier. This pin has the same voltage range as -IN.
-IN B	6	Inverting input B of the amplifier. The voltage range is from $V_{S-}$ to $V_{S+} - 2.0V$ .
+IN B	5	Non-inverting input B of the amplifier. This pin has the same voltage range as -IN.
OUT A	1	Amplifier Output, channel A
OUT B	7	Amplifier Output, channel B
$V_{S-}$	4	Negative power supply. It is normally tied to ground. It can also be tied to a voltage other than ground as long as the voltage between $V_{S+}$ and $V_{S-}$ is from 3.0V to 36V.
$V_{S+}$	8	Positive power supply. The voltage is from 3.0V to 36V. Split supplies are possible as long as the voltage between $V_{S+}$ and $V_{S-}$ is from 3.0V to 36V.

## Limiting Value

In accordance with the Absolute Maximum Rating System (IEC60134).

Parameter	Absolute Maximum Rating
Supply Voltage, $V_{S+}$ to $V_{S-}$	40 V
Signal Input Terminals: Voltage	$V_{S-} - 0.3V$ to $V_{S+}$
Signal Input Terminals: Current	$\pm 10$ mA
Output Short-Circuit	Continuous
Storage Temperature Range, $T_{stg}$	$-65$ °C to $+150$ °C
Junction Temperature, $T_j$	150 °C
Lead Temperature Range (Soldering 10 sec)	260 °C

## ESD Ratings

Parameter	Level	UNIT
Human body model (HBM), per ANSI/ESDA/JEDEC JS-001-2023 <sup>(1)</sup>	300	V
Charged device model (CDM), per JESD22-C101	1000	V

JEDEC document JEP157 states that 250-V CDM allows safe manufacturing with a standard ESD control process. Manufacturing with less than 250-V CDM is possible if necessary precautions are taken.

## Thermal Information

Thermal Metric	Package	Level	Unit
$\theta_{JA}$ Package Thermal Resistance	SOT23-5L	190	°C/W
	SOIC-8L	125	
	MSOP-8L	216	
	TSSOP-8L	160	

## Electrical Characteristics

$V_S = 5.0\text{ V to }36\text{ V}$ ,  $T_A = 25^\circ\text{C}$ ,  $V_{CM} = V_{OUT} = V_S/2$ , unless otherwise noted.

Parameter	Symbol	Conditions	Min.	Typ.	Max.	Unit
<b>DC PERFORMANCE</b>						
Input Offset Voltage	$V_{OS}$	$V_S = 5.0\text{V to }30\text{V}$ , $V_{CM} = 0$ , $V_{OUT} = 1.4\text{V}$		$\pm 2$	$\pm 7$	mV
		$V_S = 5.0\text{V to }30\text{V}$ , $V_{CM} = 0$ , $V_{OUT} = 1.4\text{V}$ , $T_A = -40^\circ\text{C to }+125^\circ\text{C}$			$\pm 10$	
Input Offset Voltage vs Temperature	$dV_{OS} / dT$	$T_A = -40^\circ\text{C to }125^\circ\text{C}$		$\pm 7$		$\mu\text{V}/^\circ\text{C}$
Input Bias Current	$I_B$	$V_{CM} = 0$		-20	-200	nA
		$V_{CM} = 0$ , $T_A = -40^\circ\text{C to }125^\circ\text{C}$			-500	
Input Offset Current	$I_{OS}$	$V_{CM} = 0$		5	50	nA
		$V_{CM} = 0$ , $T_A = -40^\circ\text{C to }125^\circ\text{C}$			150	
Open-loop voltage gain	$A_{VOL}$	$V_S = 15\text{V}$ , $V_{OUT} = 1.0\text{V to }11\text{V}$ $R_L > 2\text{k}\Omega$		85	100	dB
		$V_S = 15\text{V}$ , $V_{OUT} = 1.0\text{V to }11\text{V}$ $R_L > 2\text{k}\Omega$ , $T_A = -40^\circ\text{C to }+125^\circ\text{C}$	82			
<b>NOISE and DISTORTION PERFORMANCE</b>						
Input Voltage Noise Density	$e_n$	$f = 1\text{ kHz}$		40		$\text{nV}/\sqrt{\text{Hz}}$
<b>INPUT CHARACTERISTICS</b>						
Input Common Mode Voltage Range	$V_{CM}$	$V_S = 5.0\text{V to }30\text{V}$ , $T_A = -40^\circ\text{C to }+125^\circ\text{C}$	$V_{S-}$		$V_{S+} - 2$	V
Common Mode Rejection Rate	CMRR	$V_S = 5.0\text{V to }30\text{V}$ , $V_{CM} = 0\text{V}$	60	80		dB
Channel Separation		$f = 1\text{kHz to }20\text{ kHz}$		120		dB
<b>DYNAMIC PERFORMANCE</b>						
Gain-Bandwidth Product	GBP			0.5		MHz
Slew Rate	SR	$V_S = 5\text{V}$ , $G = +1$		0.2		$\text{V}/\mu\text{s}$
<b>OUTPUT CHARACTERISTICS</b>						
High Output Voltage Swing	$V_{OH}$	$V_S = 30\text{ V}$ , $R_L = 2\text{ k}\Omega$ , $T_A = -40^\circ\text{C to }+125^\circ\text{C}$	$V_{S+} - 3$			V
		$V_S = 30\text{ V}$ , $R_L = 10\text{ k}\Omega$ , $T_A = -40^\circ\text{C to }+125^\circ\text{C}$	$V_{S+} - 2$			
Low Output Voltage Swing	$V_{OL}$	$V_S = 5\text{ V}$ , $R_L = 10\text{ k}\Omega$ , $T_A = -40^\circ\text{C to }+125^\circ\text{C}$			$V_{S-} + 0.7$	V
Output Current	$I_{source}$	$V_S = 15\text{ V}$ , $V_{OUT} = 0\text{ V}$ , $V_{ID} = 1\text{ V}$	20	40		mA
		$V_S = 15\text{ V}$ , $V_{OUT} = 0\text{ V}$ , $V_{ID} = 1\text{ V}$ , $T_A = -40^\circ\text{C to }+125^\circ\text{C}$	10			
	$I_{sink}$	$V_S = 15\text{ V}$ , $V_{OUT} = 0\text{ V}$ , $V_{ID} = 1\text{ V}$ , $T_A = -40^\circ\text{C to }+125^\circ\text{C}$	5			
Short-Circuit Current	$I_{SC}$	$V_S = 15\text{ V}$		+40/-20		mA
<b>POWER SUPPLY</b>						
Operating Supply Voltage	$V_S$	$T_A = -40\text{ to }+125^\circ\text{C}$	3		36	V
Power Supply Rejection Ratio	PSRR	$V_S = 5.0\text{ V to }30\text{ V}$ , $T_A = -40^\circ\text{C to }+125^\circ\text{C}$	80	90		dB
Quiescent Current (Per amplifier)	$I_Q$	$V_S = 5.0\text{ V}$		210	620	$\mu\text{A}$
		$V_S = 30\text{ V}$		275	1050	

Typical Characteristics

$V_S = 5.0\text{ V to }36\text{ V}$ ,  $T_A = +25\text{ }^\circ\text{C}$ ,  $V_{CM} = V_{OUT} = V_S/2$ , and  $R_L = 10\text{ k}\Omega$  connected to  $V_S/2$ , unless otherwise noted.

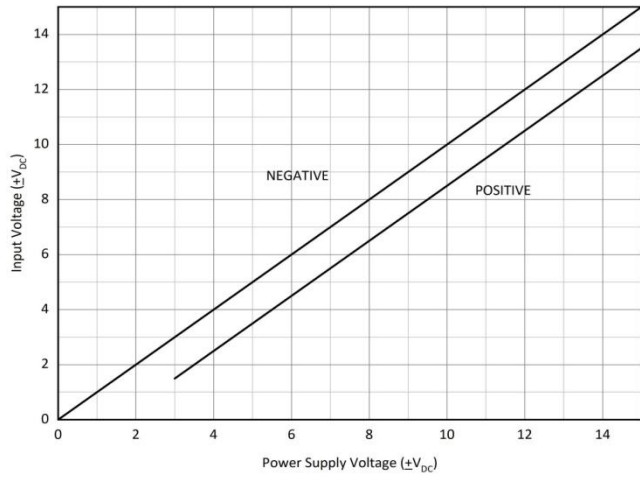

Figure 1. Input Voltage Range Vs Supply Voltage

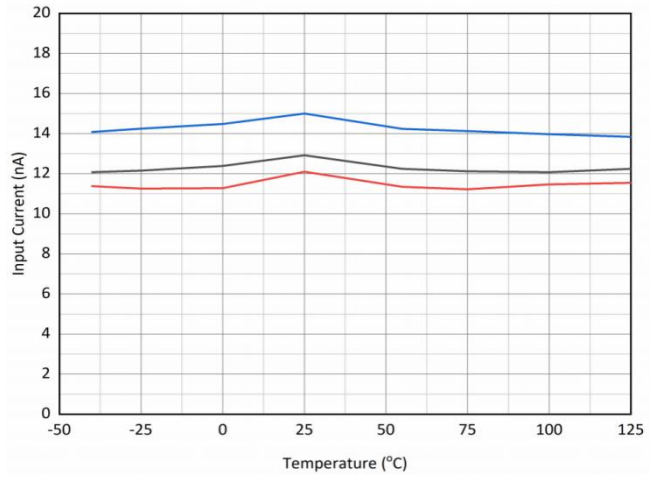

Figure 2. Input Bias Current Vs Temperature

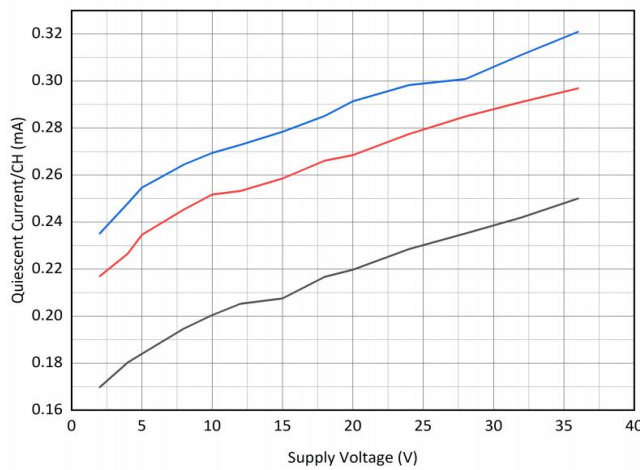

Figure 3. Quiescent Current Vs Supply Voltage

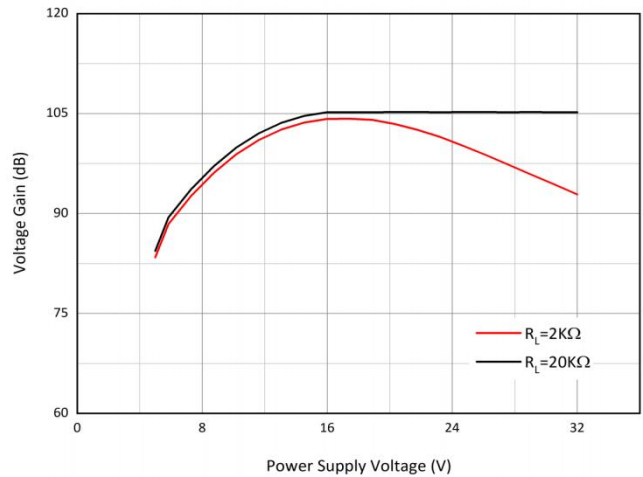

Figure 4. Open-loop Gain Vs Supply Voltage

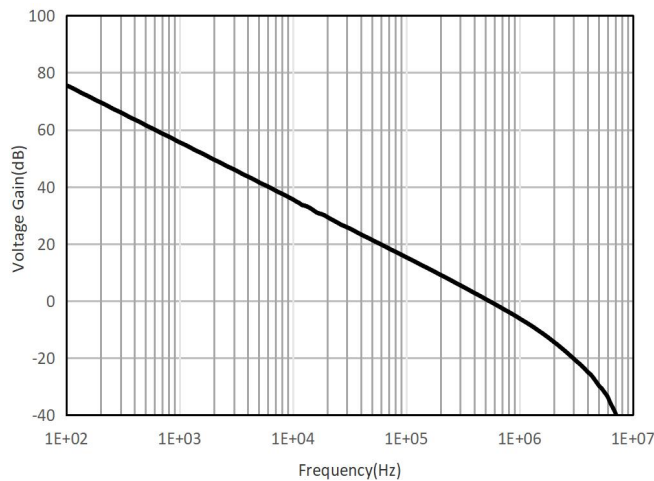

Figure 5. Open-loop Gain Vs Frequency

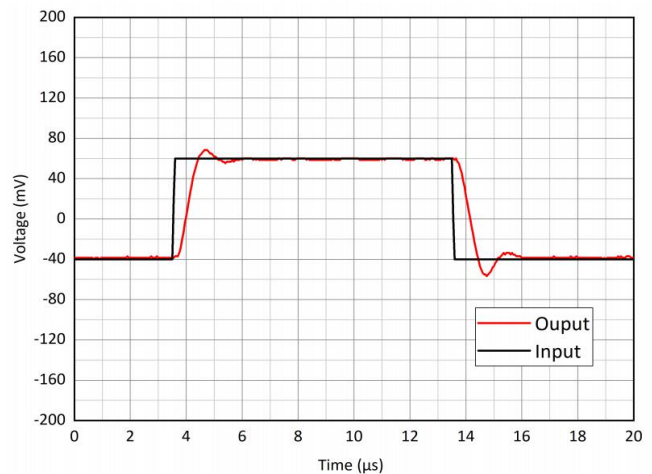

Figure 6. Small Signal Step Response

Typical Characteristics

$V_S = 5.0\text{ V to }36\text{ V}$ ,  $T_A = +25\text{ }^\circ\text{C}$ ,  $V_{CM} = V_{OUT} = V_S/2$ , and  $R_L = 10\text{ k}\Omega$  connected to  $V_S/2$ , unless otherwise noted.

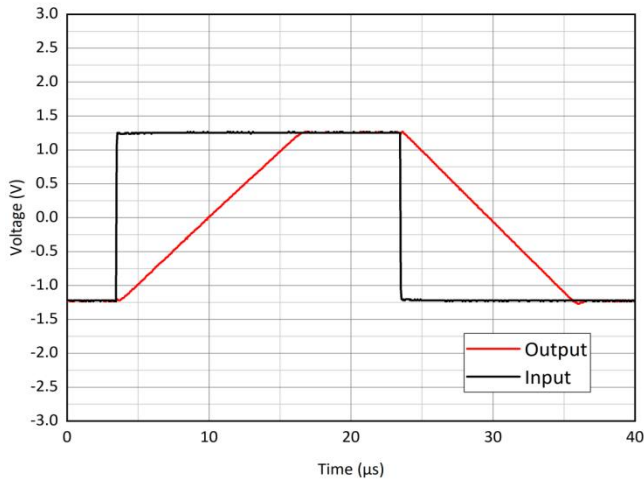

Figure 7. Large Signal Step Response

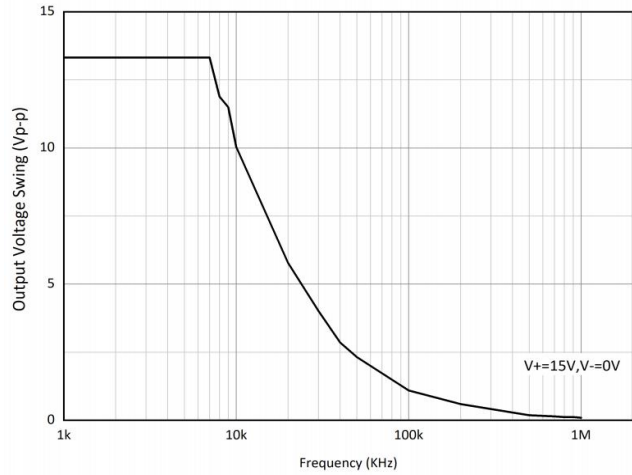

Figure 8. Output Swing Vs Frequency

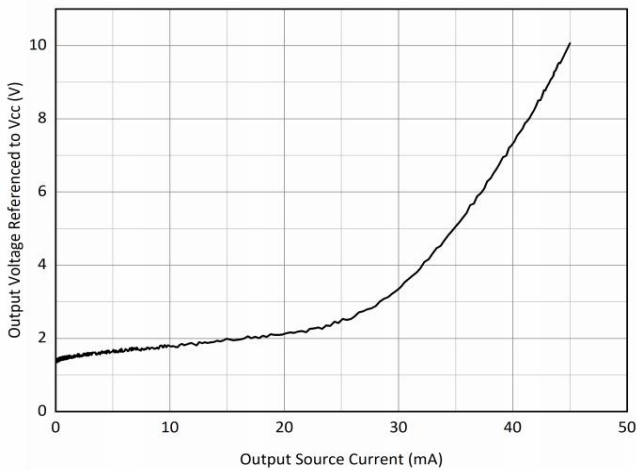

Figure 9. Output Swing to  $V_{CC}$  Vs Output Sourcing

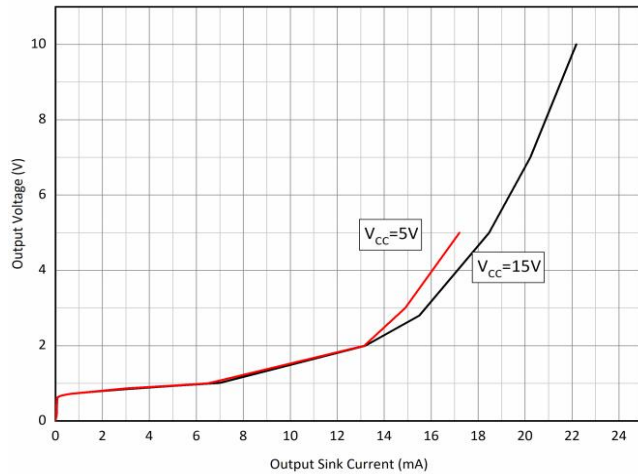

Figure 10. Output Swing Vs Output Sinking Current

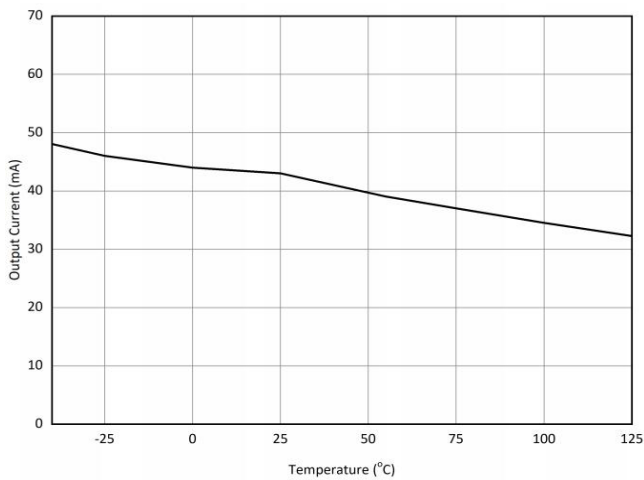
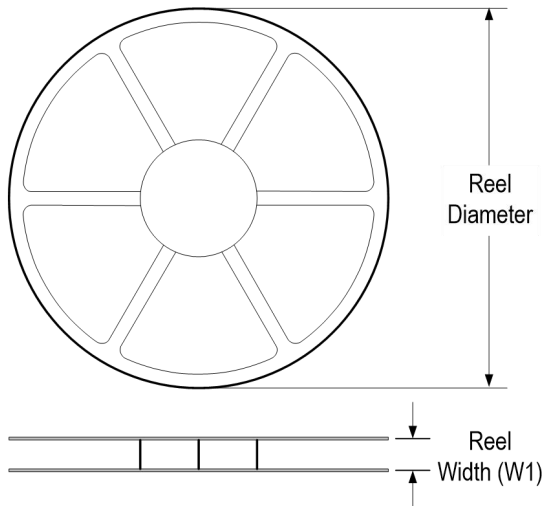

Figure 11. Output Sourcing Current Vs Temperature

Tape and Reel Information

REEL DIMENSIONS



TAPE DIMENSIONS

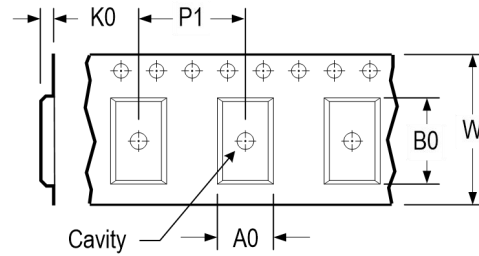

A0	Dimension designed to accommodate the component width
B0	Dimension designed to accommodate the component length
K0	Dimension designed to accommodate the component thickness
W	Overall width of the carrier tape
P1	Pitch between successive cavity centers

QUADRANT ASSIGNMENTS FOR PIN 1 ORIENTATION IN TAPE

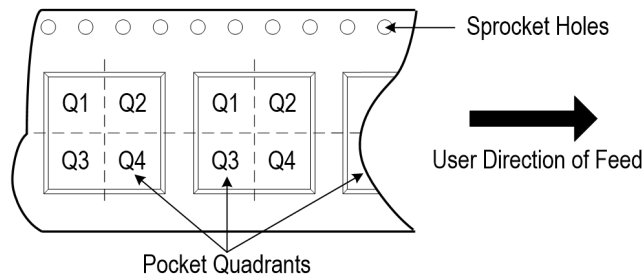

\* All dimensions are nominal

Device	Package Type	Pins	SPQ	Reel Diameter (mm)	Reel Width W1 (mm)	A0 (mm)	B0 (mm)	K0 (mm)	P1 (mm)	W (mm)	Pin 1 Quadrant
LTA321XT5/R6	SOT23	5	3 000	178	9.0	3.3	3.2	1.5	4.0	8.0	Q3
LTA323XT5/R6	SOT23	5	3 000	178	9.0	3.3	3.2	1.5	4.0	8.0	Q3
LTA2904LXS8/R8	SOIC	8	4 000	330	12.4	6.6	5.3	2.0	8.0	12.0	Q1
LTA2904LXT8/R8	TSSOP	8	4 000	330	12.4	6.5	4.0	1.2	8.0	12.0	Q1
LTA2904LXV8/R6	MSOP	8	3 000	330	12.4	5.0	3.5	2.0	8.0	12.0	Q1

Package Outlines

DIMENSIONS, TSSOP-8L

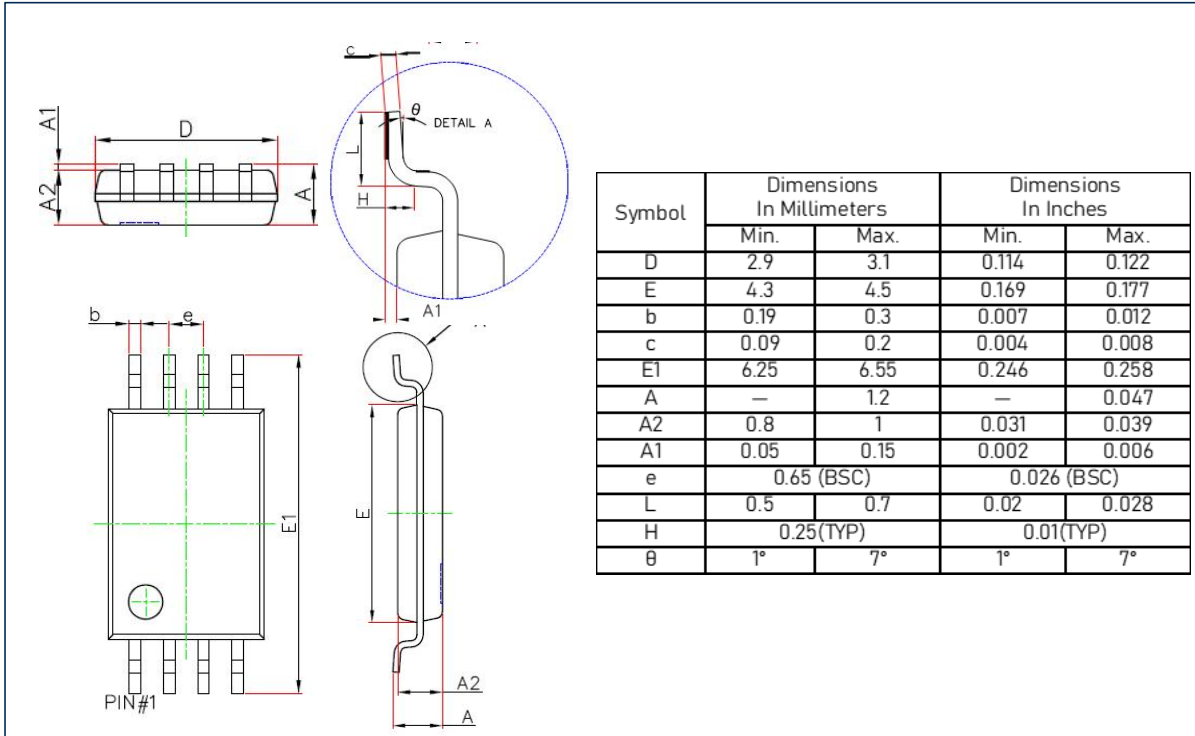

RECOMMENDED SOLDERING FOOTPRINT, TSSOP-8L

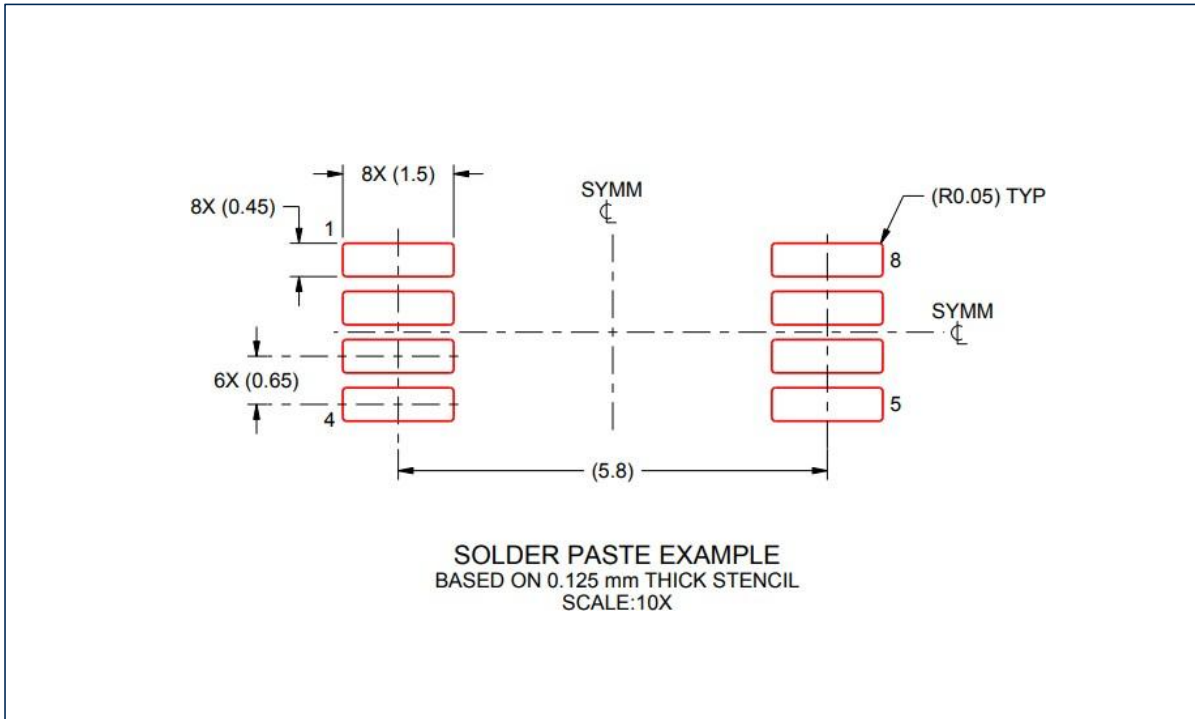

Package Outlines (cont.)

DIMENSIONS, SOIC-8L

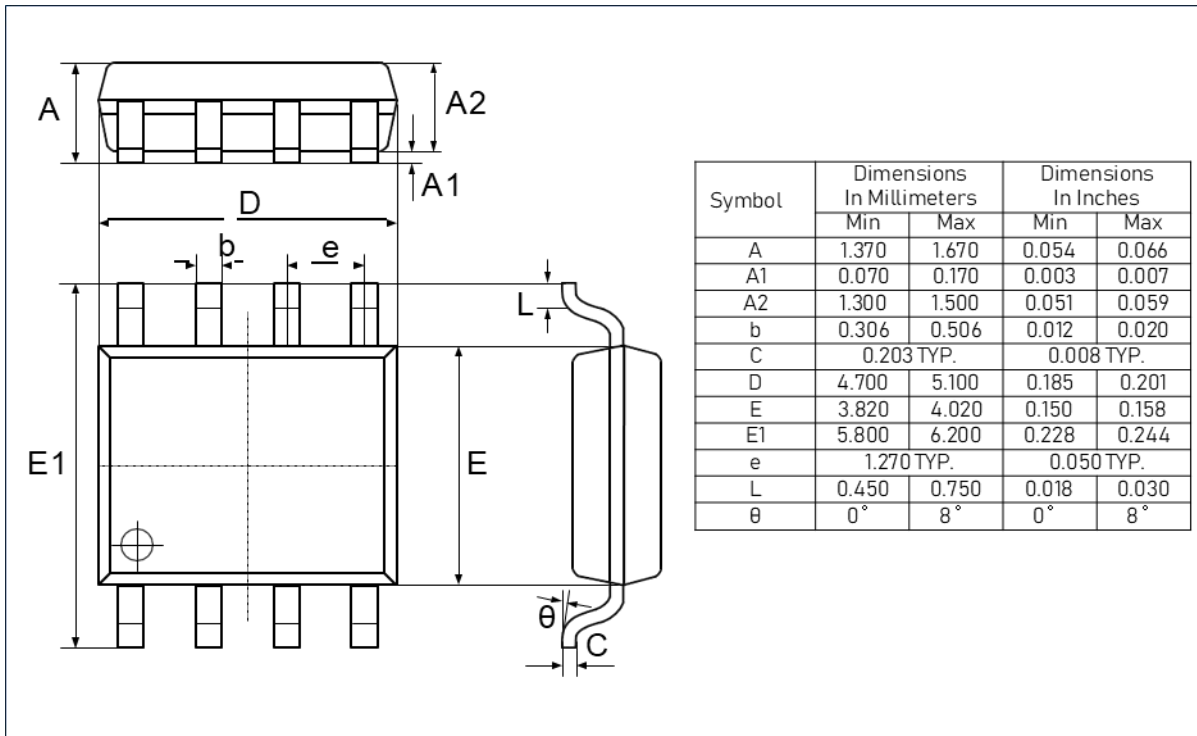

RECOMMENDED SOLDERING FOOTPRINT, SOIC-8L

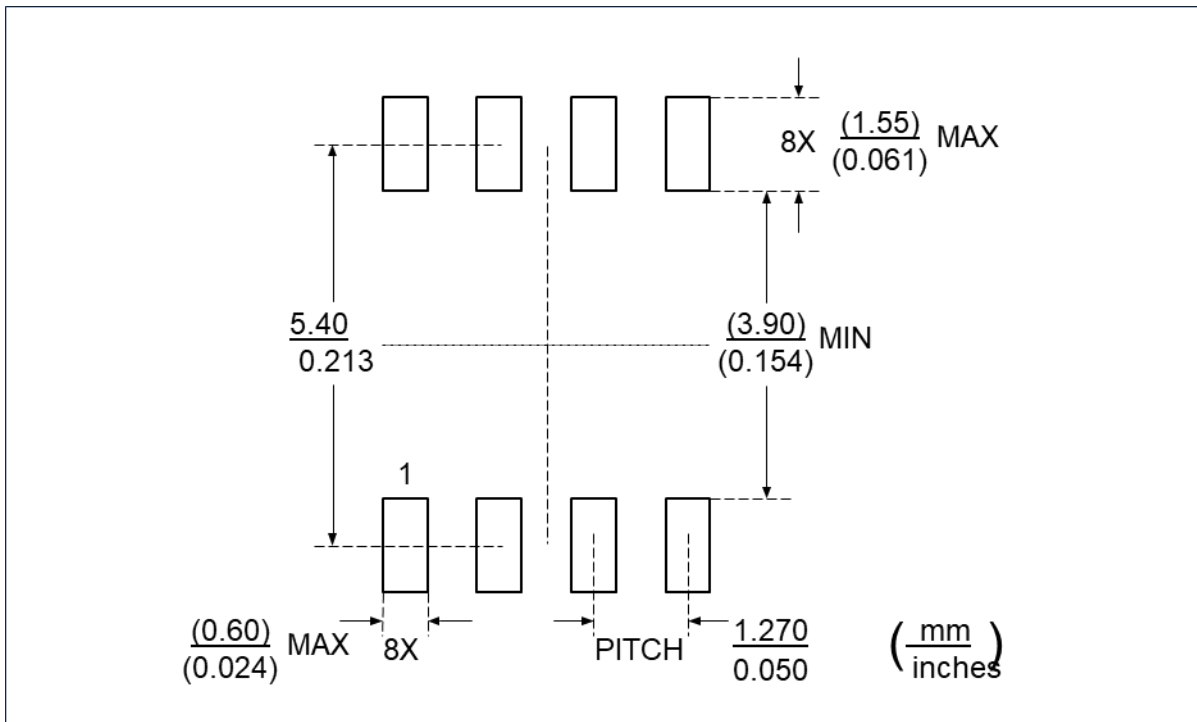

Package Outlines (cont.)

DIMENSIONS, MSOP-8L

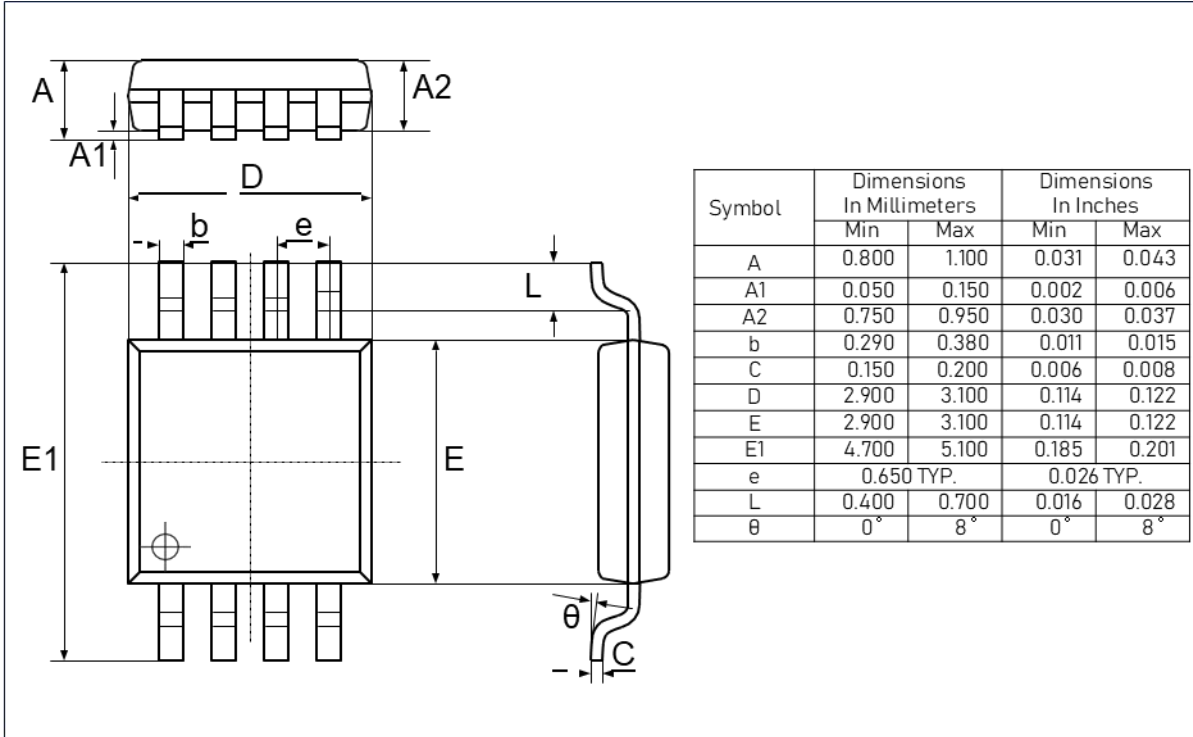

RECOMMENDED SOLDERING FOOTPRINT, MSOP-8L

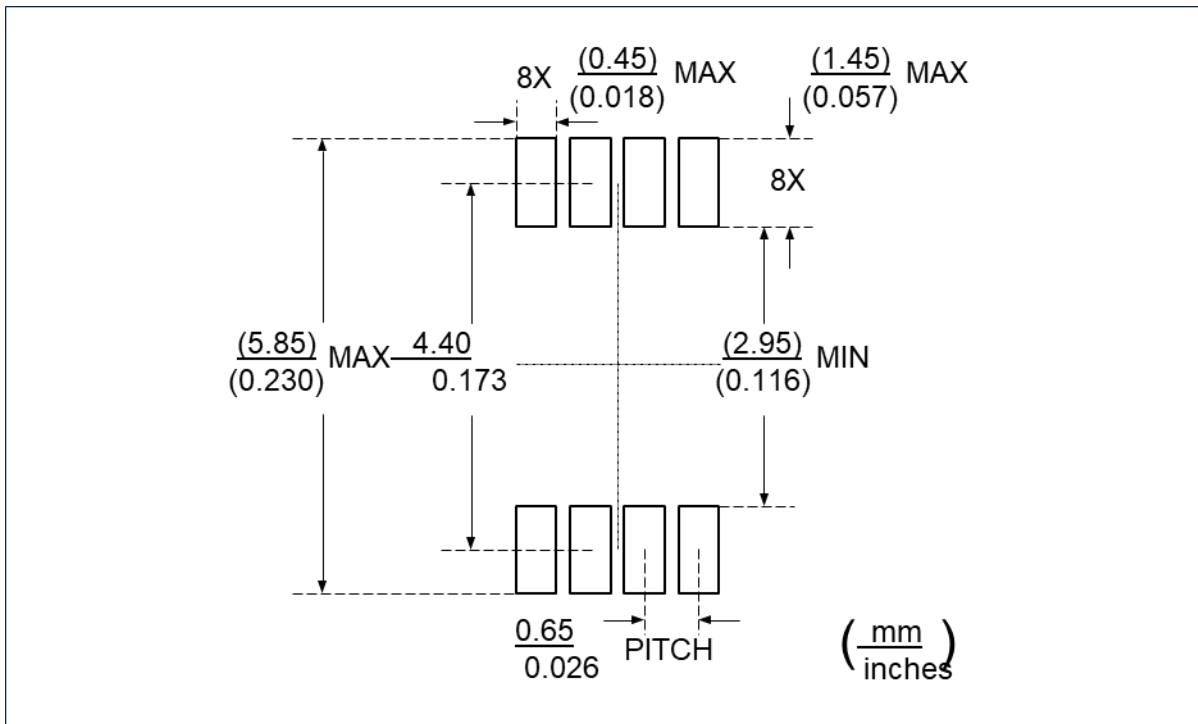

Package Outlines (Cont.)

DIMENSIONS, SOT23-5L

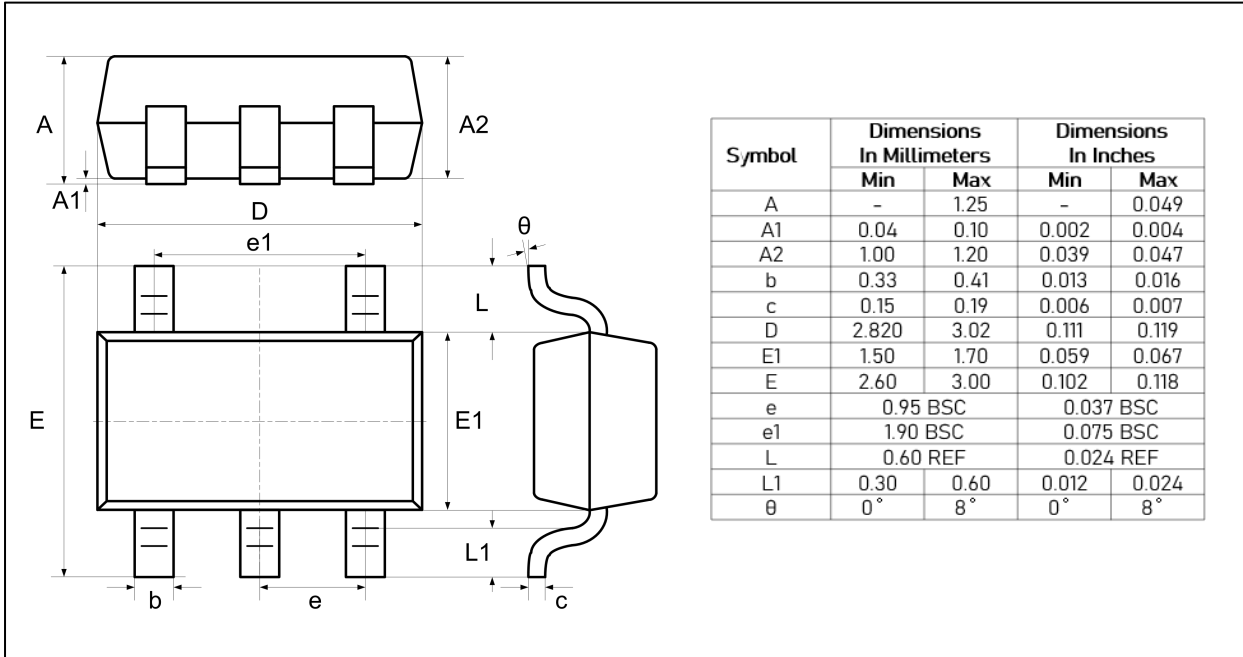

RECOMMENDED SOLDERING FOOTPRINT, SOT23-5L

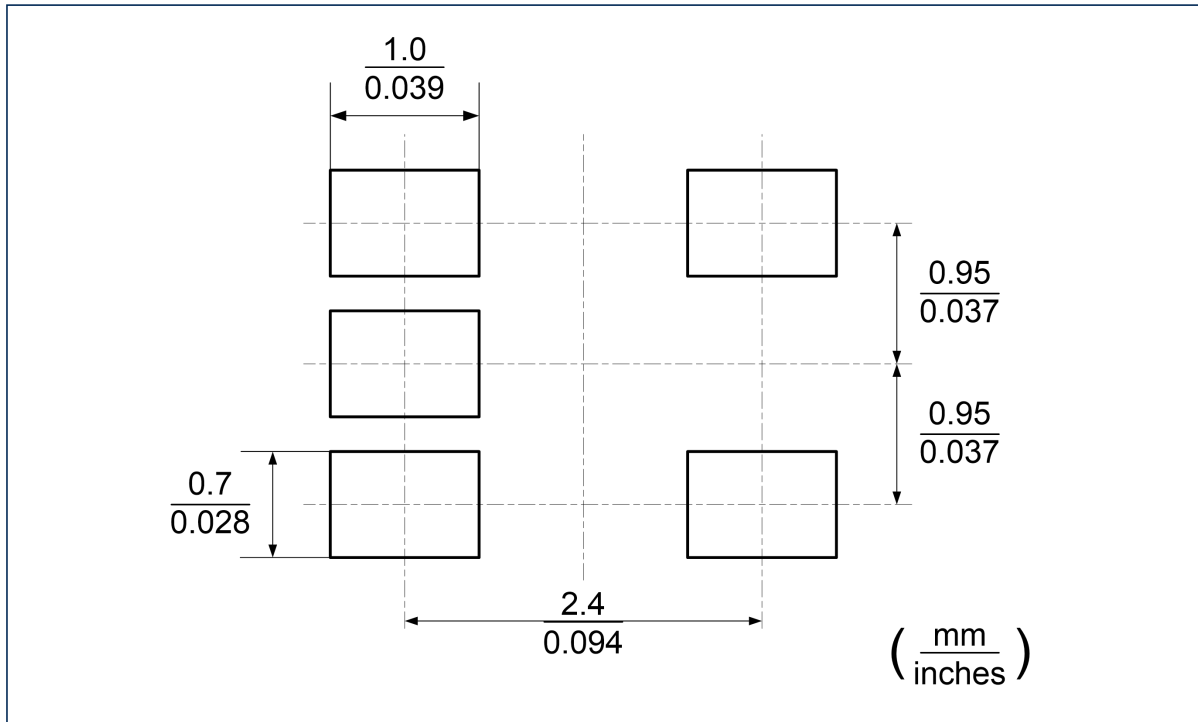

## Important Notice

---

Linearin is a global fabless semiconductor company specializing in advanced high-performance high-quality analog/mixed-signal IC products and sensor solutions. The company is devoted to the innovation of high performance, analog-intensive sensor front-end products and modular sensor solutions, applied in multi-market of medical & wearable devices, smart home, sensing of IoT, intelligent industrial & smart factory (industry 4.0), and automotives. Linearin's product families include widely-used standard catalog products, solution-based application specific standard products (ASSPs) and sensor modules that help customers achieve faster time-to-market products. Go to <http://www.linearin.com> for a complete list of Linearin product families.

For additional product information, or full datasheet, please contact with the Linearin's Sales Department or Representatives.