

General Description

The LTA806x family (LTA8061, LTA8062, and LTA8064) is a new generation of high voltage (48 V), low noise, precision operational amplifiers. These devices offer outstanding dc precision and ac performance, include low offset ($\pm 100 \mu\text{V}$ maximum), low drift ($\pm 1 \mu\text{V}/^\circ\text{C}$), 1.1-MHz bandwidth, and 22 nV/ $\sqrt{\text{Hz}}$ Input voltage noise density at 10 kHz. Unique features such as differential input-voltage range to the negative supply rail, high output current ($\pm 40 \text{ mA}$), and high capacitive load drive of up to 1 nF make the LTA806x high-performance op-amps for high-voltage industrial applications.

The robust design of the LTA806x family provides ease-of-use to the circuit designer: integrated RF/EMI rejection filter, no phase reversal in overdrive conditions, and high electro-static discharge (ESD) protection. The LTA806x are optimized for operation at voltages from +4.5 V ($\pm 2.25 \text{ V}$) to +48 V ($\pm 24 \text{ V}$) over the extended temperature range of -40°C to $+125^\circ\text{C}$.

The LTA8061 (single) is available in both SOT23-5L and SOIC-8L packages. The LTA8062 (dual) is offered in SOIC-8L and MSOP-8L packages. The quad-channel LTA8064 is offered in both SOIC-14L and TSSOP-14L packages.

Features and Benefits

- Wide Supply: $\pm 2.25 \text{ V}$ to $\pm 24 \text{ V}$, 4.5 V to 48 V
- Low Offset Voltage: $\pm 100 \mu\text{V}$ Maximum
- Low Offset Voltage Drift: $\pm 1 \mu\text{V}/^\circ\text{C}$
- Bandwidth: 1.1 MHz GBW
- Slew Rate: 0.8 V/ μs
- Low Noise: 22 nV/ $\sqrt{\text{Hz}}$ at 10 kHz
- High Common-Mode Rejection: 110 dB
- Low Bias Current: $\pm 20 \text{ pA}$
- EMI/RFI Filtered Inputs

Applications

- High-side and low-side current sensing
- Analog input and output modules
- ADC driver and reference buffer amplifier
- High Precision Comparator
- Power delivery: UPS, server, and merchant network power
- Multiplexed Data-Acquisition Systems
- Test and Measurement Equipment
- Programmable Logic Controllers

Pin Configuration (Top View)

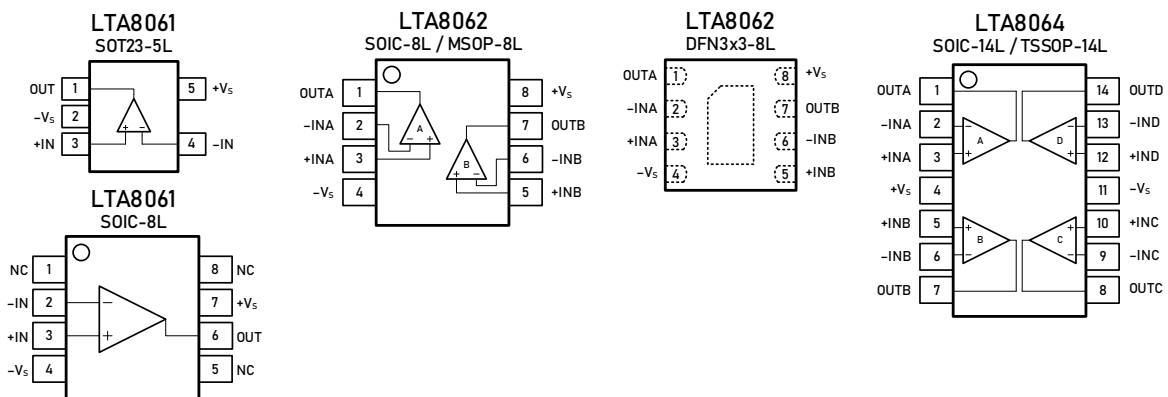

Pin Description

Symbol	Description
-IN	Inverting input of the amplifier. The voltage range is from V_{S-} to $V_{S+} - 2V$.
+IN	Non-inverting input of the amplifier. This pin has the same voltage range as -IN.
+ V_S	Positive power supply. The voltage is from 4.5V to 48V. Split supplies are possible as long as the voltage between V_{S+} and V_{S-} is from 4.5V to 48V.
- V_S	Negative power supply. It is normally tied to ground. It can also be tied to a voltage other than ground as long as the voltage between V_{S+} and V_{S-} is from 4.5V to 48V.
OUT	Amplifier output.
NC	No connection

Ordering Information ⁽¹⁾

Type Number	Package Name	Package Quantity	Eco Class ⁽²⁾	Marking Code ⁽³⁾
LTA8061XT5/R6	SOT23-5L	Tape and Reel, 3 000	Green (RoHS & no Sb/Br)	H61
LTA8061XS8/R8	SOIC-8L	Tape and Reel, 4 000	Green (RoHS & no Sb/Br)	HV-61
LTA8062XS8/R8	SOIC-8L	Tape and Reel, 4 000	Green (RoHS & no Sb/Br)	HV-62
LTA8062XV8/R6	MSOP-8L	Tape and Reel, 3 000	Green (RoHS & no Sb/Br)	HV62
LTA8062XF8/R6	DFN3x3-8L	Tape and Reel, 3 000	Green (RoHS & no Sb/Br)	HV62
LTA8064XS14/R5	SOIC-14L	Tape and Reel, 2 500	Green (RoHS & no Sb/Br)	HV-64
LTA8064XT14/R6	TSSOP-14L	Tape and Reel, 3 000	Green (RoHS & no Sb/Br)	HV-64

(1) Please contact to your Linearin representative for the latest availability information and product content details.

(2) Eco Class - The planned eco-friendly classification: Pb-Free (RoHS) or Green (RoHS & Halogen Free).

(3) There may be multiple device markings, a varied marking character of "x", or additional marking, which relates to the logo, the lot trace code information, or the environmental category on the device.

Limiting Value - In accordance with the Absolute Maximum Rating System (IEC 60134).

Parameter	Absolute Maximum Rating
Supply Voltage, V_{S+} to V_{S-}	60 V
Signal Input Terminals: Voltage, Current	$-V_S - 0.3 V$ to $+V_S + 0.3 V$, ± 10 mA
Output Short-Circuit	Continuous
Storage Temperature Range, T_{stg}	-65 °C to $+150$ °C
Junction Temperature, T_J	150 °C
Lead Temperature Range (Soldering 10 sec)	260 °C

ESD Rating

Parameter	Item	Value	Unit
Electrostatic Discharge Voltage	Human body model (HBM), per MIL-STD-883J / Method 3015.9 ⁽¹⁾	$\pm 1\ 500$	V
	Charged device model (CDM), per ESDA/JEDEC JS-002-2014 ⁽²⁾	$\pm 1\ 000$	
	Machine model (MM), per JESD22-A115C	± 400	

(1) JEDEC document JEP155 states that 500-V HBM allows safe manufacturing with a standard ESD control process. Manufacturing with less than 500-V HBM is possible if necessary precautions are taken.

(2) JEDEC document JEP157 states that 250-V CDM allows safe manufacturing with a standard ESD control process. Manufacturing with less than 250-V CDM is possible if necessary precautions are taken.

Electrical Characteristics

$V_S = 4.5\text{ V to }48\text{ V}$, $T_A = +25\text{ }^\circ\text{C}$, $V_{CM} = V_S/2$, $V_O = V_S/2$, and $R_L = 10\text{ k}\Omega$ connected to $V_S/2$, unless otherwise noted. Boldface limits apply over the specified temperature range, $T_A = -40\text{ }^\circ\text{C to }+125\text{ }^\circ\text{C}$.

Symbol	Parameter	Conditions	Min.	Typ.	Max.	Unit
OFFSET VOLTAGE						
V_{OS}	Input offset voltage				± 100	μV
$V_{OS\ TC}$	Offset voltage drift	$T_A = -40\text{ to }+125\text{ }^\circ\text{C}$		± 1		$\mu\text{V}/^\circ\text{C}$
PSRR	Power supply rejection ratio	$V_S = 4.5\text{ to }44\text{ V}$, $V_{CM} = 0.1\text{ V}$		2		$\mu\text{V/V}$
		$T_A = -40\text{ to }+125\text{ }^\circ\text{C}$		6		
INPUT BIAS CURRENT						
I_B	Input bias current			20		pA
		$T_A = +85\text{ }^\circ\text{C}$		150		
		$T_A = +125\text{ }^\circ\text{C}$		600		
I_{OS}	Input offset current			10		pA
NOISE						
V_n	Input voltage noise	$f = 0.1\text{ to }10\text{ Hz}$		4		μV_{P-P}
e_n	Input voltage noise density	$f = 1\text{ kHz}$		25		$\text{nV}/\sqrt{\text{Hz}}$
		$f = 10\text{ kHz}$		22		
I_n	Input current noise density	$f = 1\text{ kHz}$		5		$\text{fA}/\sqrt{\text{Hz}}$
INPUT VOLTAGE						
V_{CM}	Common-mode voltage range		$-V_S$		$+V_S - 2$	V
CMRR	Common-mode rejection ratio	$V_S = 40\text{ V}$, $V_{CM} = 0\text{ to }38\text{ V}$		110		dB
		$V_{CM} = 0.1\text{ to }38\text{ V}$, $T_A = -40\text{ to }+125\text{ }^\circ\text{C}$		98		
		$V_S = 5.0\text{ V}$, $V_{CM} = 0\text{ to }3\text{ V}$		85		
		$V_{CM} = 0.1\text{ to }3\text{ V}$, $T_A = -40\text{ to }+125\text{ }^\circ\text{C}$		72		
INPUT IMPEDANCE						
C_{IN}	Input capacitance	Differential		2.0		pF
		Common mode		3.5		
OPEN-LOOP GAIN						
A_{VOL}	Open-loop voltage gain	$V_S = 40\text{ V}$, $V_O = 0.1\text{ to }39.9\text{ V}$		116		dB
		$T_A = -40\text{ to }+125\text{ }^\circ\text{C}$		112		
		$V_S = 5\text{ V}$, $V_O = 0.1\text{ to }4.9\text{ V}$		101		
		$T_A = -40\text{ to }+125\text{ }^\circ\text{C}$		97		
FREQUENCY RESPONSE						
GBW	Gain bandwidth product			1.1		MHz
SR	Slew rate	$V_S = 40\text{ V}$, $G = +1$, 10 V step		0.8		$\text{V}/\mu\text{s}$
THD+N	Total harmonic distortion + noise	$G = +1$, $f = 1\text{ kHz}$, $V_O = 3\text{ V}_{RMS}$		0.02		%
t_S	Settling time	To 0.1%, $V_S = 40\text{ V}$, $G = +1$, 5 V step		6		μs
		To 0.01%, $V_S = 40\text{ V}$, $G = +1$, 5 V step		12		
t_{OR}	Overload recovery time	$V_{IN} \times \text{Gain} > V_S$		3		μs

CAUTION: These devices are sensitive to electrostatic discharge; follow proper IC Handling Procedures.
Linearin and designs are registered trademarks of Linearin Technology Corporation.
© Copyright Linearin Technology Corporation. All Rights Reserved.
All other trademarks mentioned are the property of their respective owners.

Electrical Characteristics (continued)

$V_S = 4.5\text{ V to }48\text{ V}$, $T_A = +25\text{ }^\circ\text{C}$, $V_{CM} = V_S/2$, $V_O = V_S/2$, and $R_L = 10\text{ k}\Omega$ connected to $V_S/2$, unless otherwise noted. Boldface limits apply over the specified temperature range, $T_A = -40\text{ }^\circ\text{C to }+125\text{ }^\circ\text{C}$.

Symbol	Parameter	Conditions	Min.	Typ.	Max.	Unit
OUTPUT						
V_{OH}	High output voltage swing	$V_S = \pm 20\text{ V}$, $R_L = 10\text{ k}\Omega$		$+V_S - 97$		mV
		$V_S = \pm 20\text{ V}$, $R_L = 2\text{ k}\Omega$		$+V_S - 257$		
V_{OL}	Low output voltage swing	$V_S = \pm 20\text{ V}$, $R_L = 10\text{ k}\Omega$		$-V_S + 52$		mV
		$V_S = \pm 20\text{ V}$, $R_L = 2\text{ k}\Omega$		$-V_S + 232$		
I_{SC}	Short-circuit current			± 40		mA
POWER SUPPLY						
V_S	Operating supply voltage	$T_A = -40\text{ to }+125\text{ }^\circ\text{C}$	4.5		48	V
I_Q	Quiescent current (per amplifier)	$V_S = 5\text{ V}$		150		μA
		$V_S = 40\text{ V}$		220		
THERMAL CHARACTERISTICS						
T_A	Operating temperature range		-40		+125	$^\circ\text{C}$
θ_{JA}	Package Thermal Resistance	SOT23-5L		190		$^\circ\text{C/W}$
		MSOP-8L		201		
		SOIC-8L		125		
		TSSOP-14L		112		
		DFN3x3		65		
		SOIC-14L		115		

Typical Performance Characteristics

At $T_A = +25^\circ\text{C}$, $V_{CM} = V_S/2$, and $R_L = 10\text{ k}\Omega$ connected to $V_S/2$, unless otherwise noted.

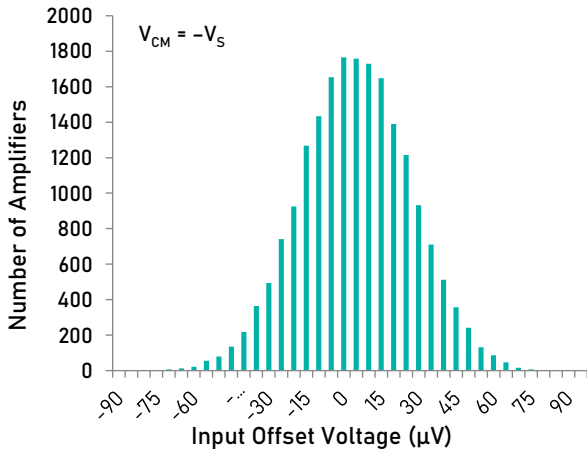

Offset Voltage Production Distribution

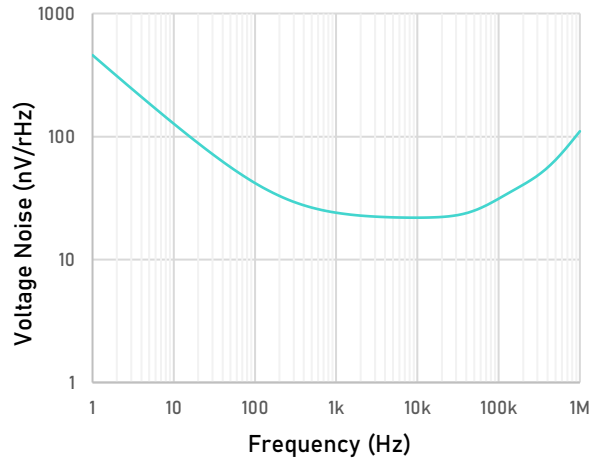

Input Voltage Noise Spectral Density as a function of Frequency

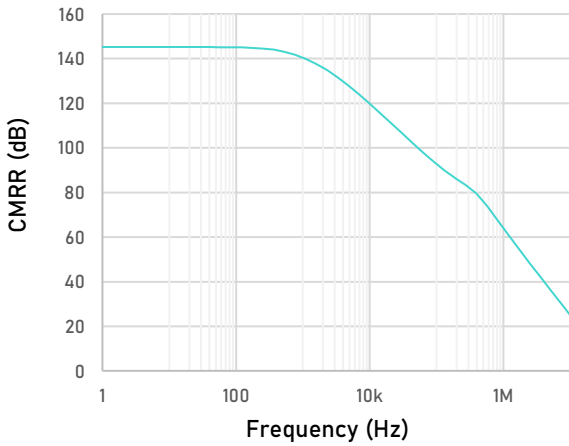

CMRR as a function of Frequency

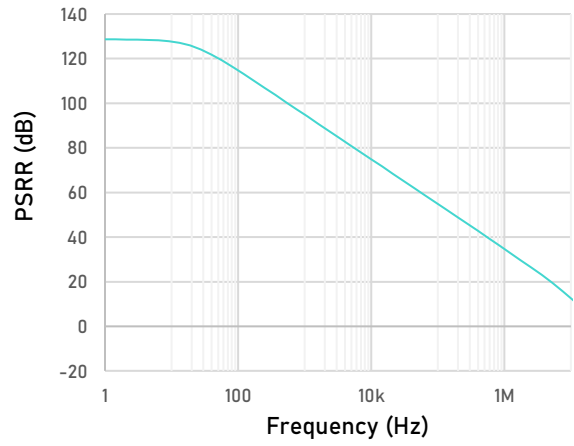

PSRR as a function of Frequency

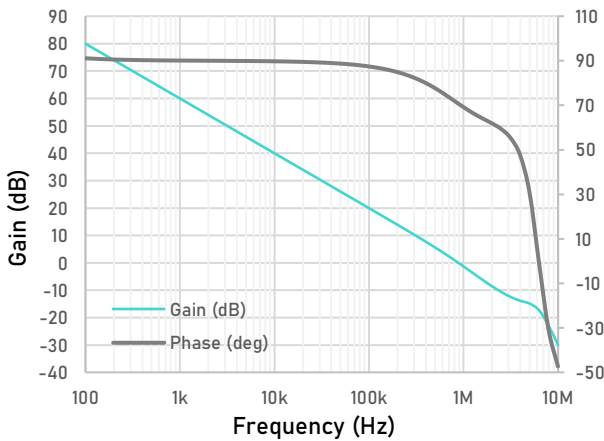

Open-loop Gain and Phase as a function of Frequency

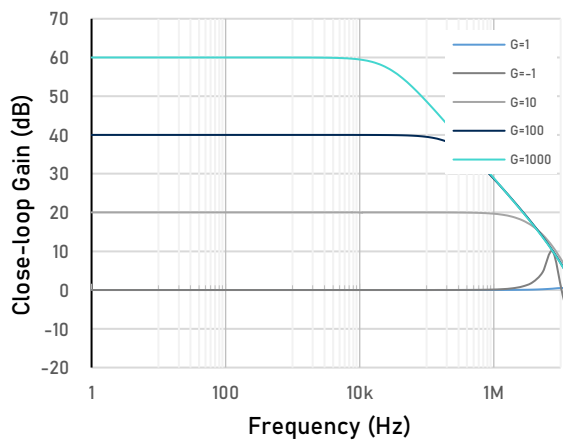

Close-loop Gain as a function of Frequency

CAUTION: These devices are sensitive to electrostatic discharge; follow proper IC Handling Procedures.
Linearin and designs are registered trademarks of Linearin Technology Corporation.
© Copyright Linearin Technology Corporation. All Rights Reserved.
All other trademarks mentioned are the property of their respective owners.

Typical Performance Characteristics (Continued)

At $T_A = +25^\circ\text{C}$, $V_{CM} = V_S/2$, and $R_L = 10\text{ k}\Omega$ connected to $V_S/2$, unless otherwise noted.

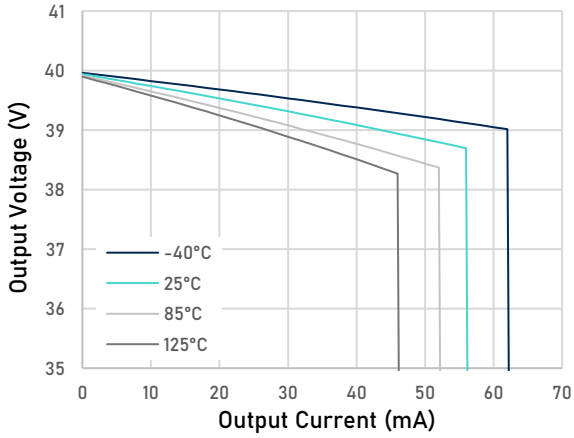

Output Voltage Swing as a function of Output Current (Sourcing, $V_S = 40\text{ V}$)

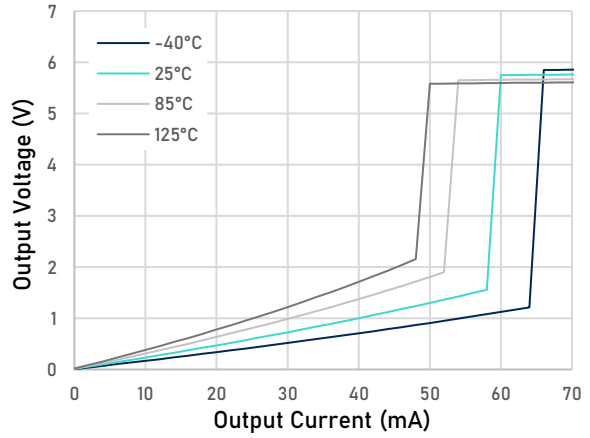

Output Voltage Swing as a function of Output Current (Sinking, $V_S = 40\text{ V}$)

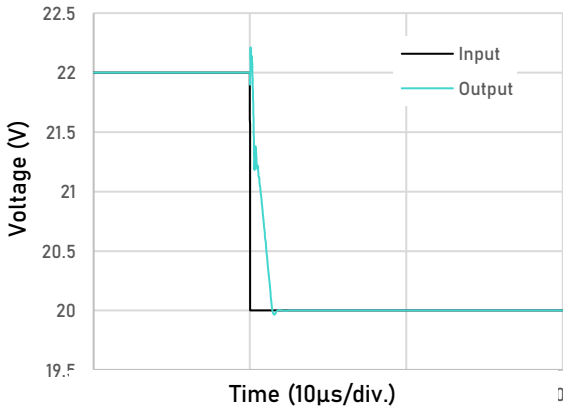

Large-Signal Step Response(Failing)

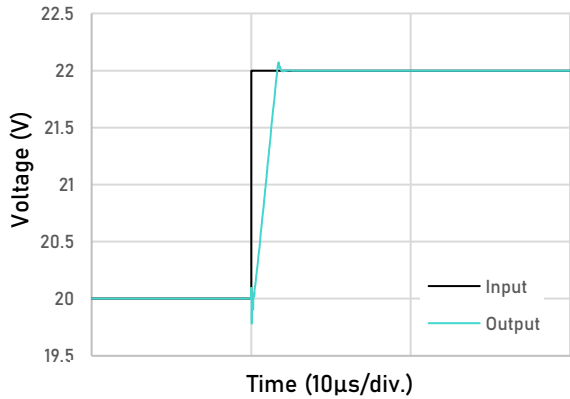

Large-Signal Step Response(Rising)

Tape and Reel Information

REEL DIMENSIONS

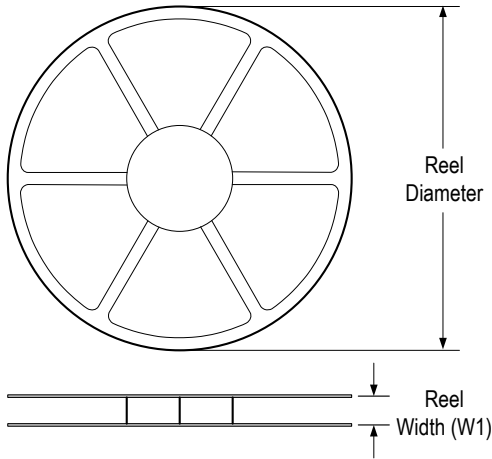

TAPE DIMENSIONS

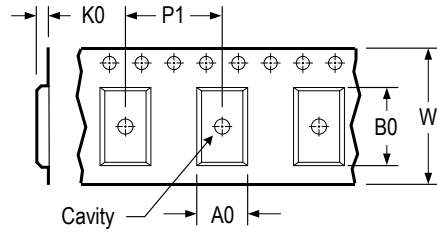

A0	Dimension designed to accommodate the component width
B0	Dimension designed to accommodate the component length
K0	Dimension designed to accommodate the component thickness
W	Overall width of the carrier tape
P1	Pitch between successive cavity centers

QUADRANT ASSIGNMENTS FOR PIN 1 ORIENTATION IN TAPE

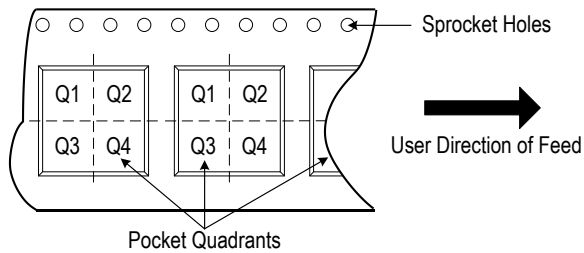

* All dimensions are nominal

Device	Package Type	Pins	SPQ	Reel Diameter (mm)	Reel Width W1 (mm)	A0 (mm)	B0 (mm)	K0 (mm)	P1 (mm)	W (mm)	Pin 1 Quadrant
LTA8291XT5/R6	SOT23	5	3 000	178	9.0	3.3	3.2	1.5	4.0	8.0	Q3

Package Outlines

DIMENSIONS, SOT23-5L

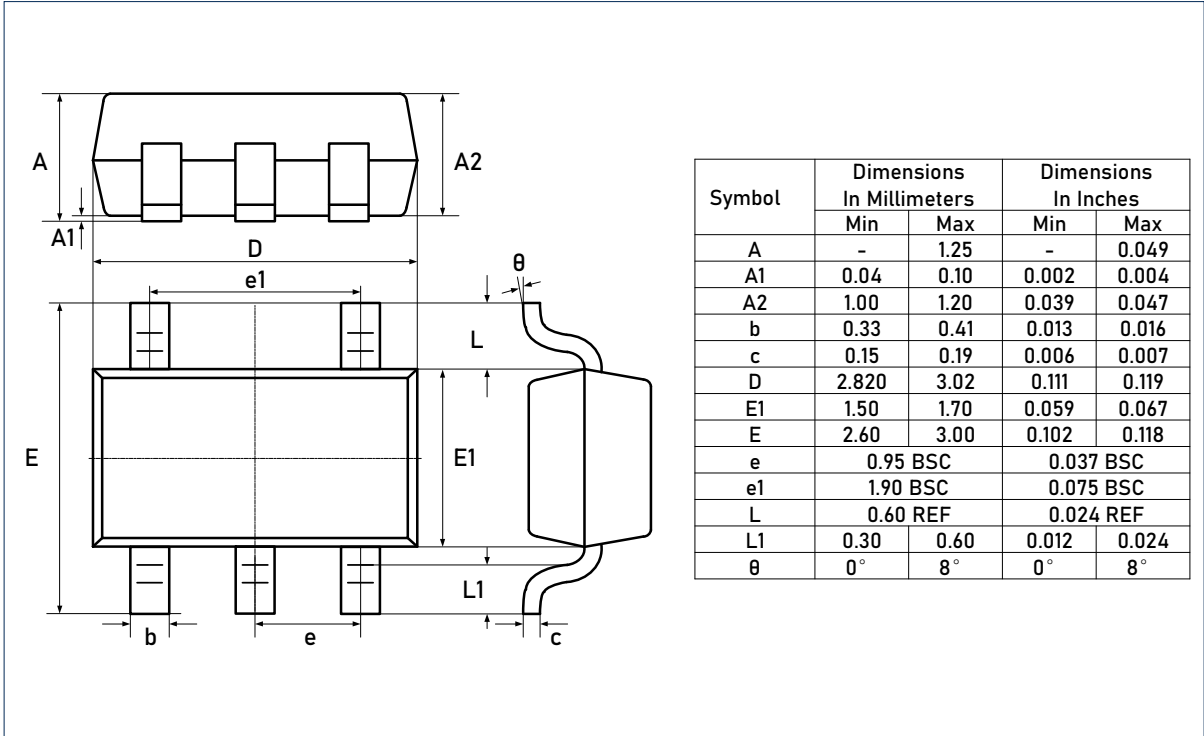

RECOMMENDED SOLDERING FOOTPRINT, SOT23-5L

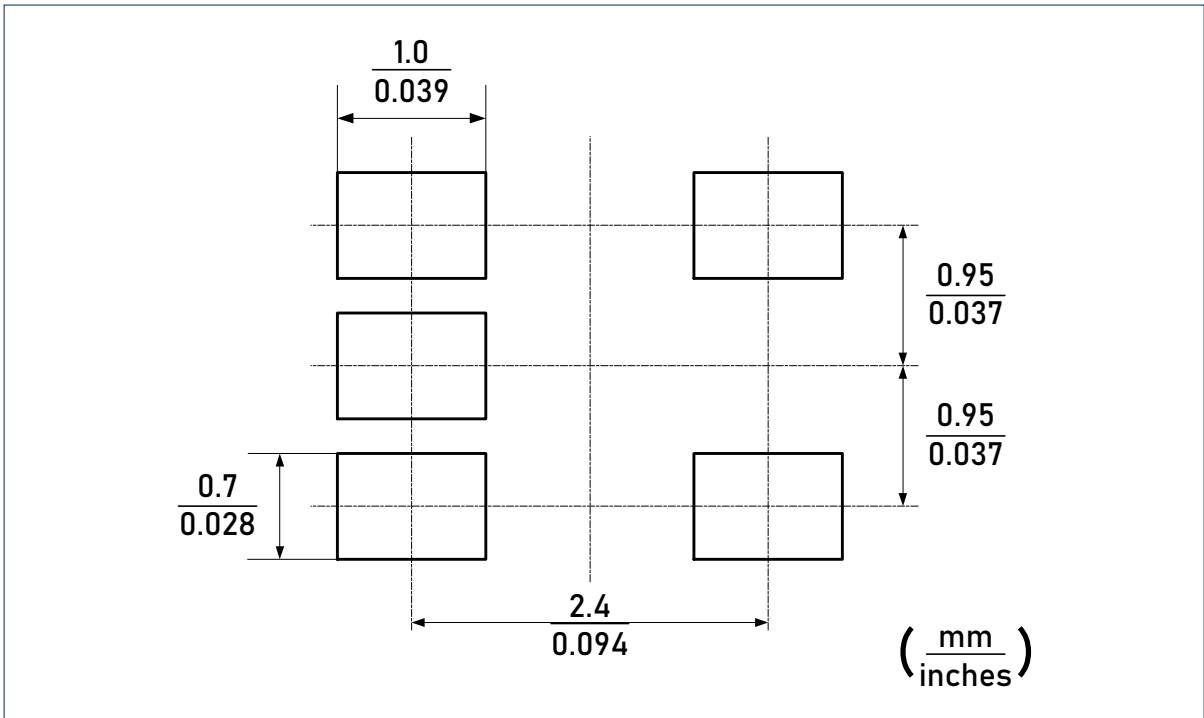

CAUTION: These devices are sensitive to electrostatic discharge; follow proper IC Handling Procedures.
Linearin and designs are registered trademarks of Linearin Technology Corporation.
© Copyright Linearin Technology Corporation. All Rights Reserved.
All other trademarks mentioned are the property of their respective owners.

Package Outlines (continued)

DIMENSIONS, SOIC-8L

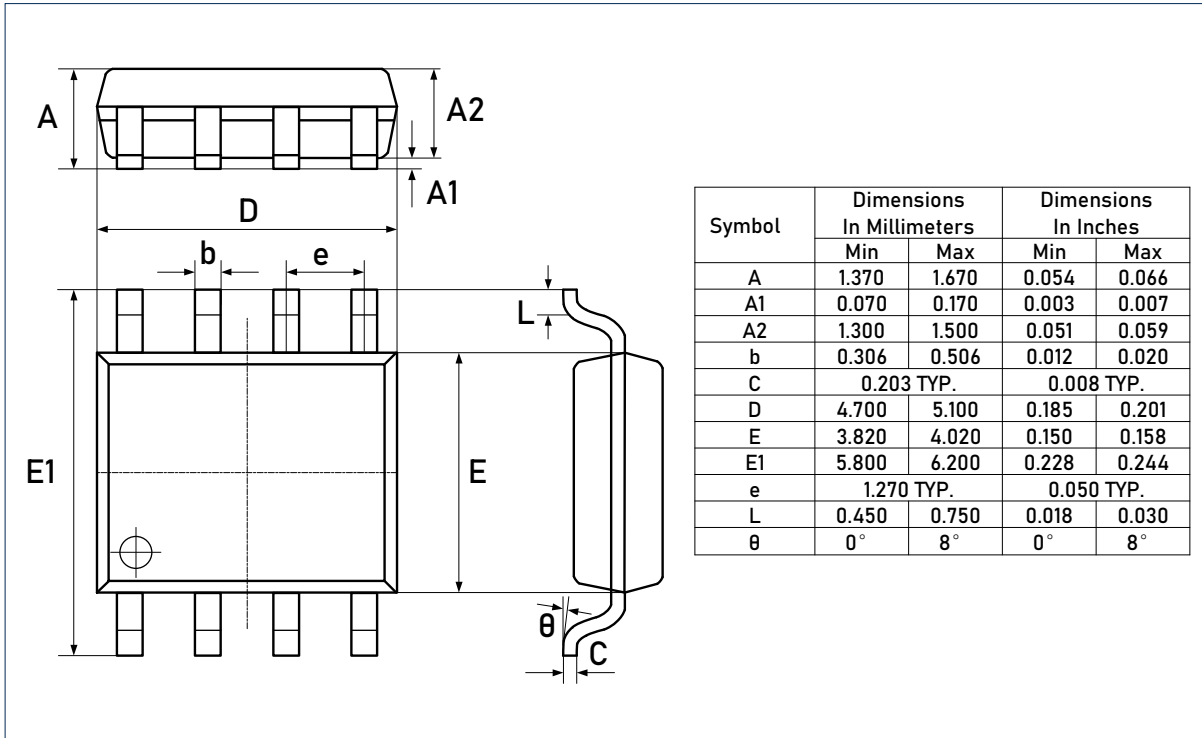

RECOMMENDED SOLDERING FOOTPRINT, SOIC-8L

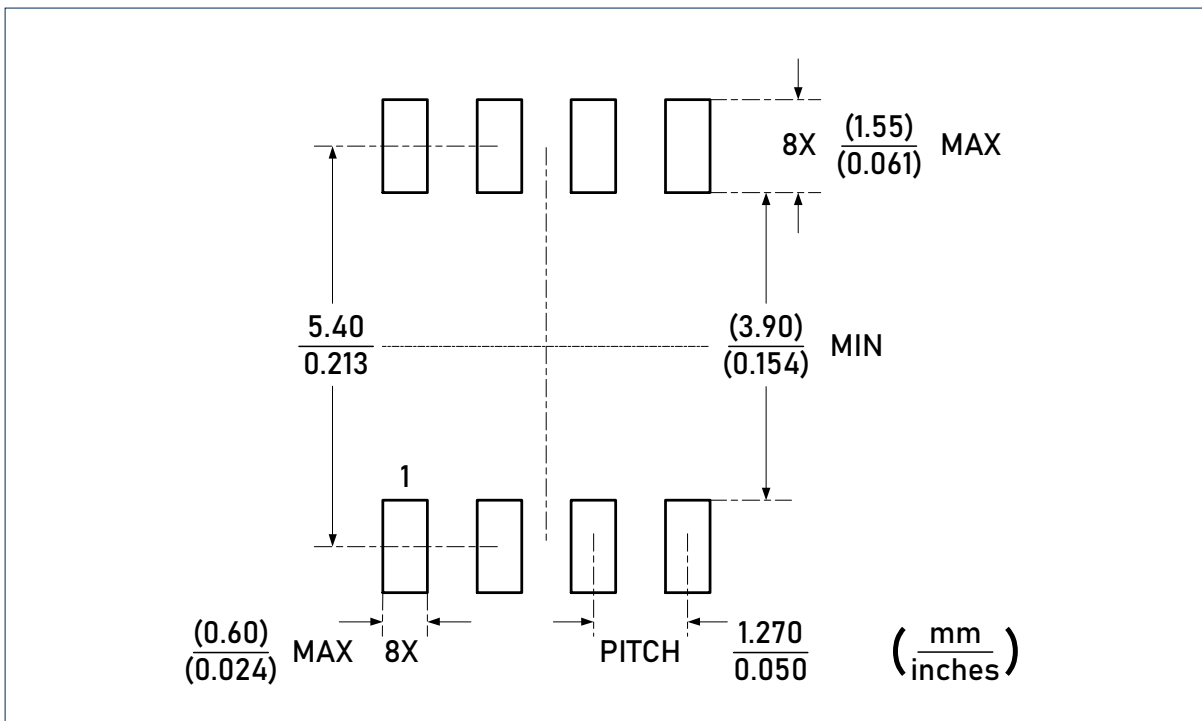

CAUTION: These devices are sensitive to electrostatic discharge; follow proper IC Handling Procedures.
 Linearin and designs are registered trademarks of Linearin Technology Corporation.
 © Copyright Linearin Technology Corporation. All Rights Reserved.
 All other trademarks mentioned are the property of their respective owners.

Package Outlines (continued)

DIMENSIONS, MSOP-8L

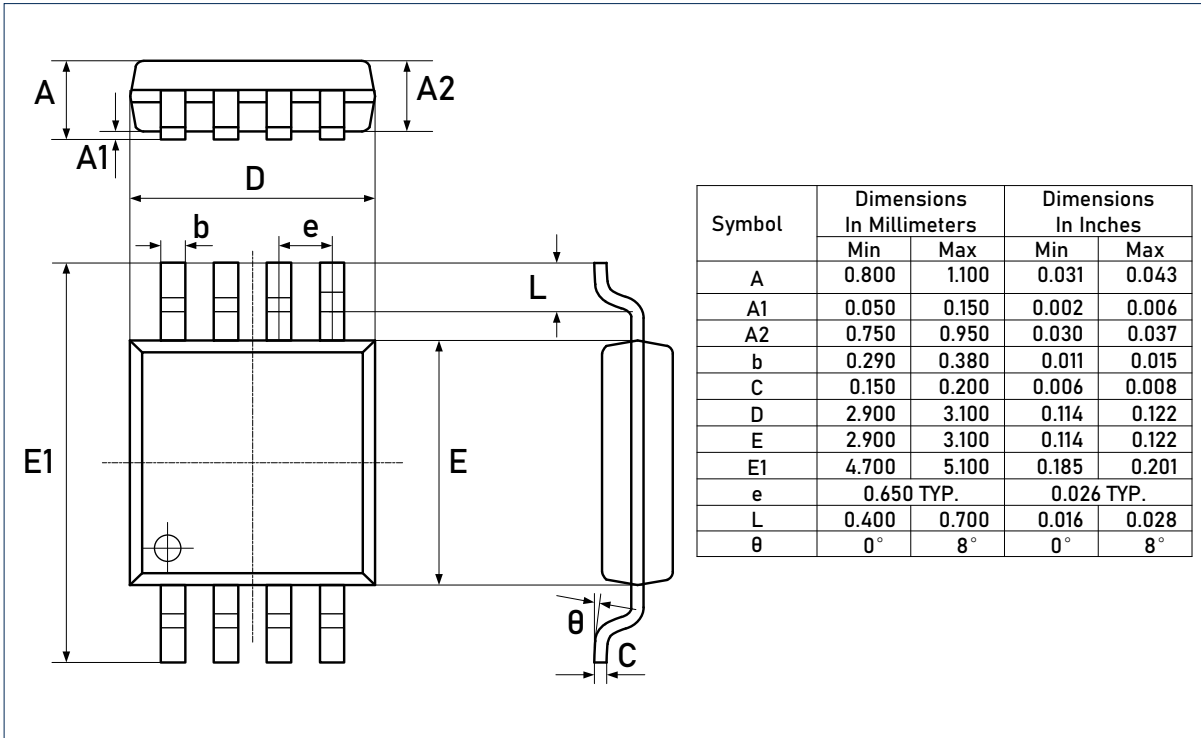

RECOMMENDED SOLDERING FOOTPRINT, MSOP-8L

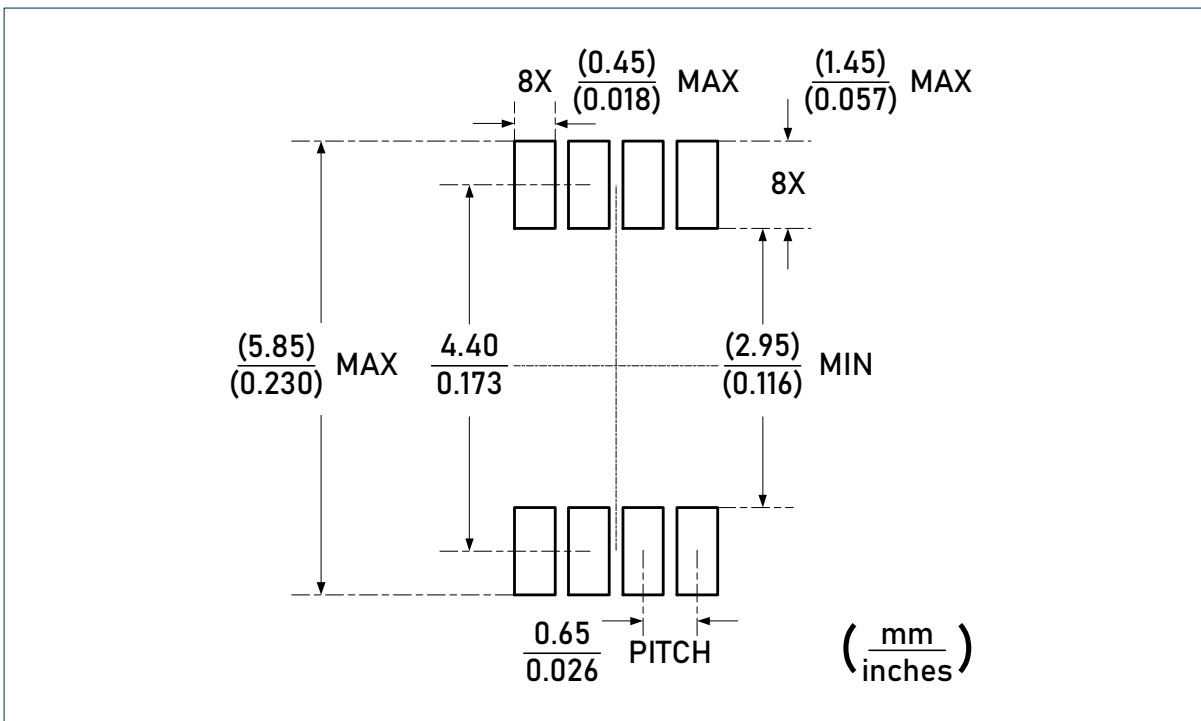

CAUTION: These devices are sensitive to electrostatic discharge; follow proper IC Handling Procedures.
 Linearin and designs are registered trademarks of Linearin Technology Corporation.
 © Copyright Linearin Technology Corporation. All Rights Reserved.
 All other trademarks mentioned are the property of their respective owners.

Package Outlines (continued)

DIMENSIONS, DFN3x3-8L

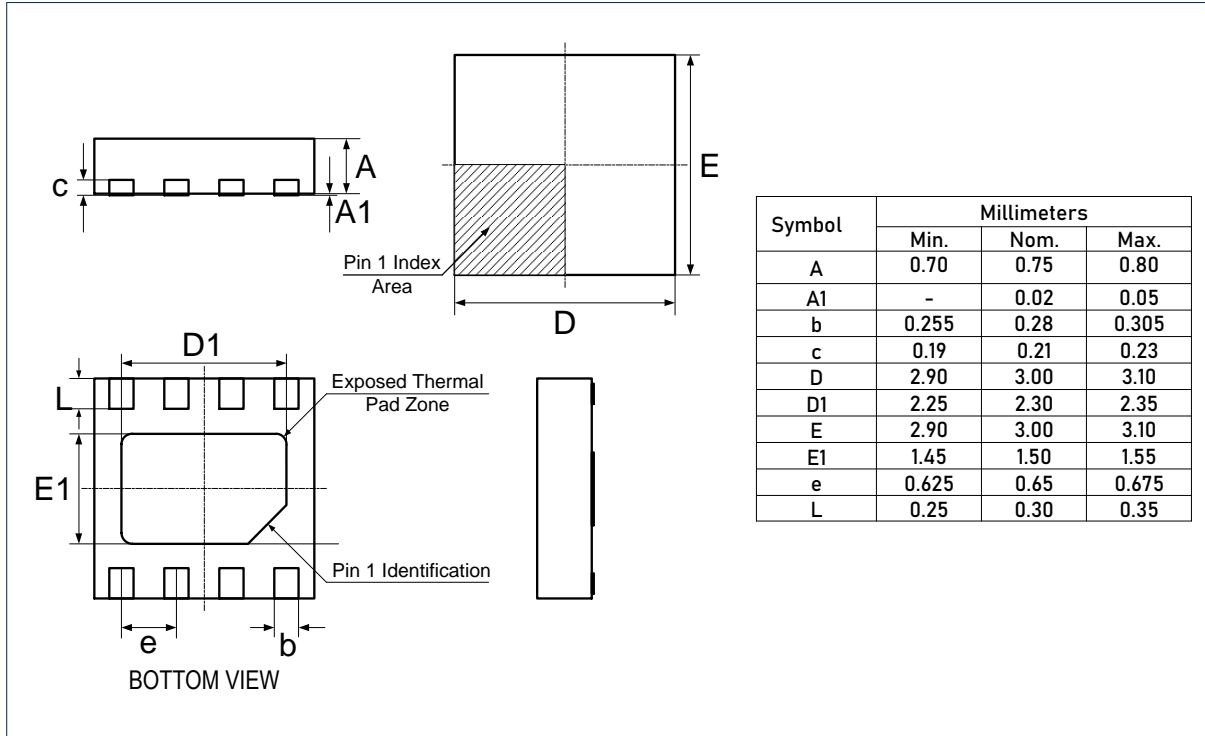

Package Outlines (continued)

DIMENSIONS, SOIC-14L

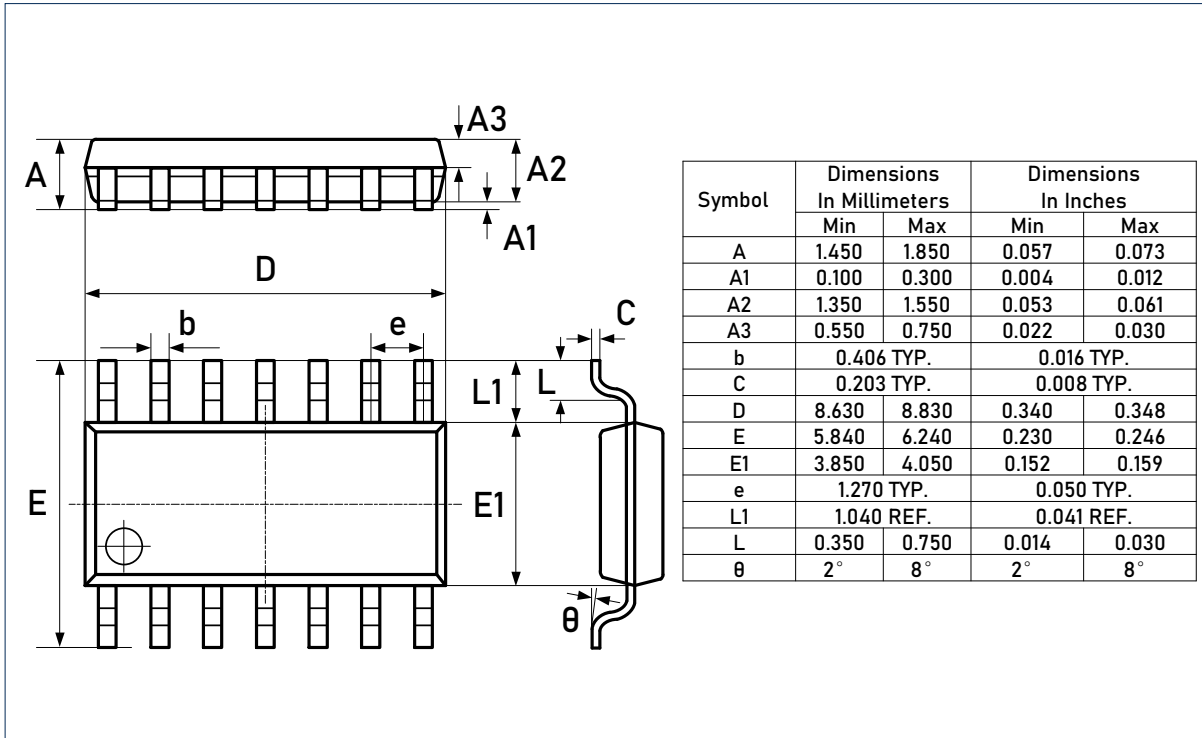

RECOMMENDED SOLDERING FOOTPRINT, SOIC-14L

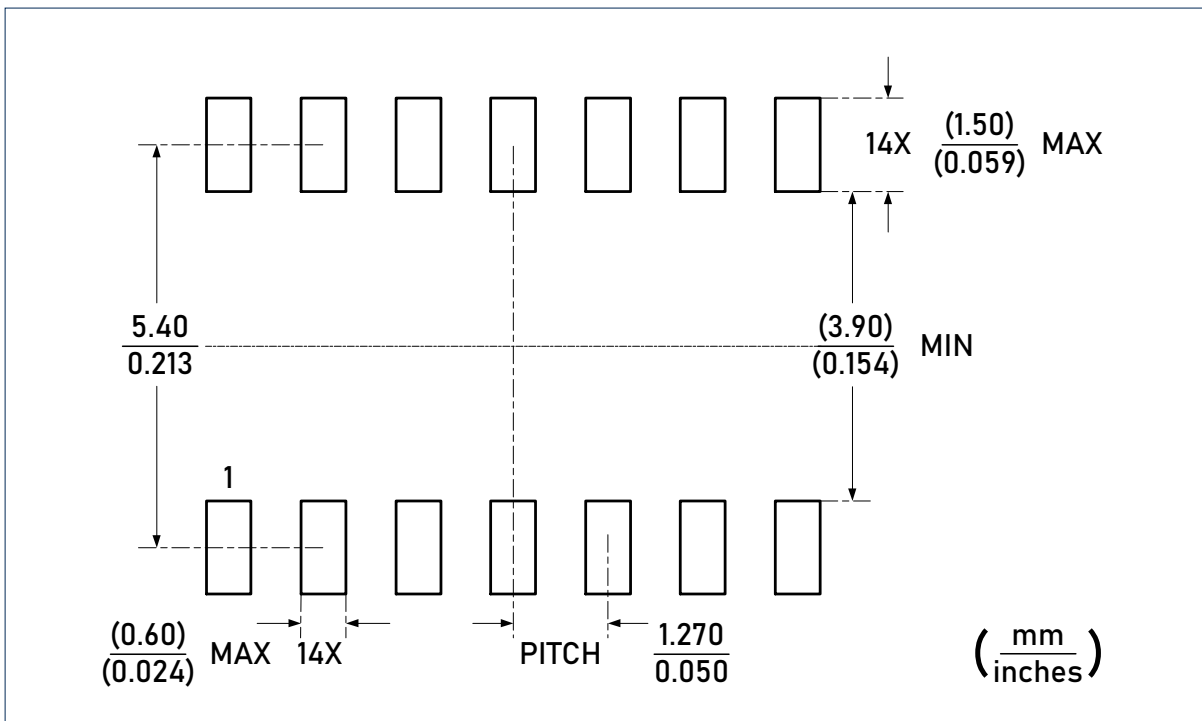

CAUTION: These devices are sensitive to electrostatic discharge; follow proper IC Handling Procedures.
Linearin and designs are registered trademarks of Linearin Technology Corporation.
© Copyright Linearin Technology Corporation. All Rights Reserved.
All other trademarks mentioned are the property of their respective owners.

Package Outlines (continued)

DIMENSIONS, TSSOP-14L

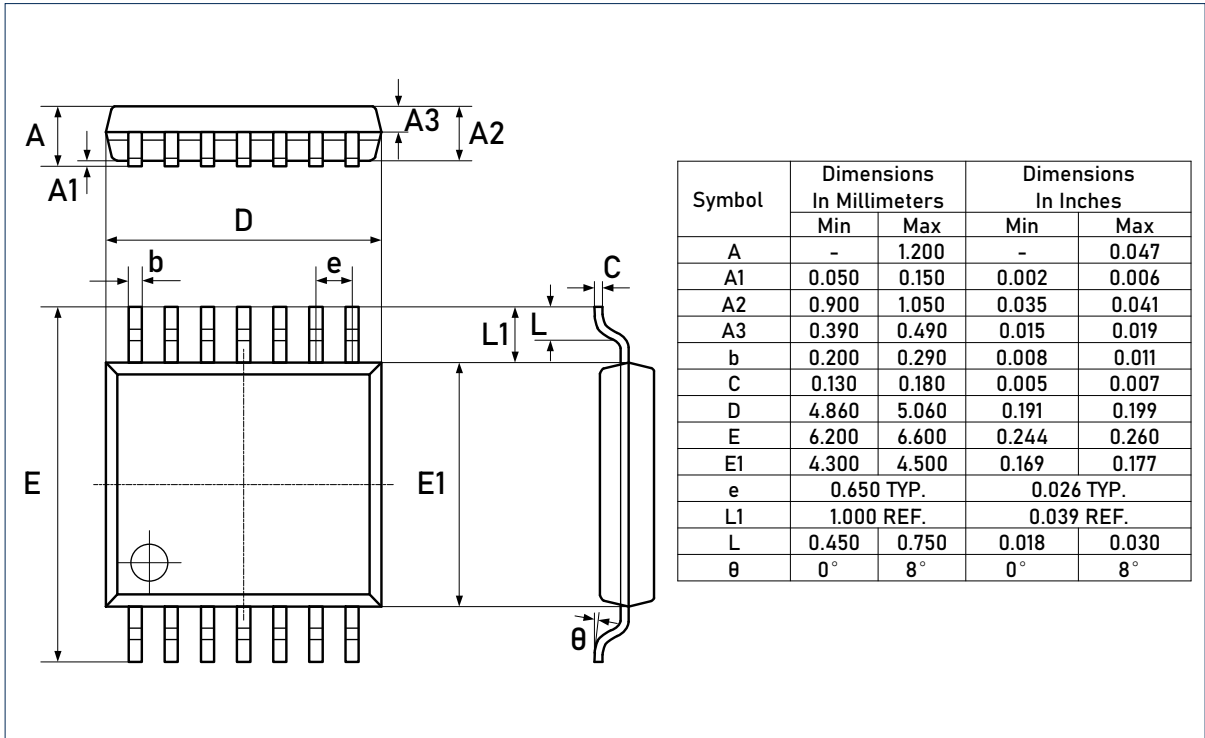

RECOMMENDED SOLDERING FOOTPRINT, SOIC-14L

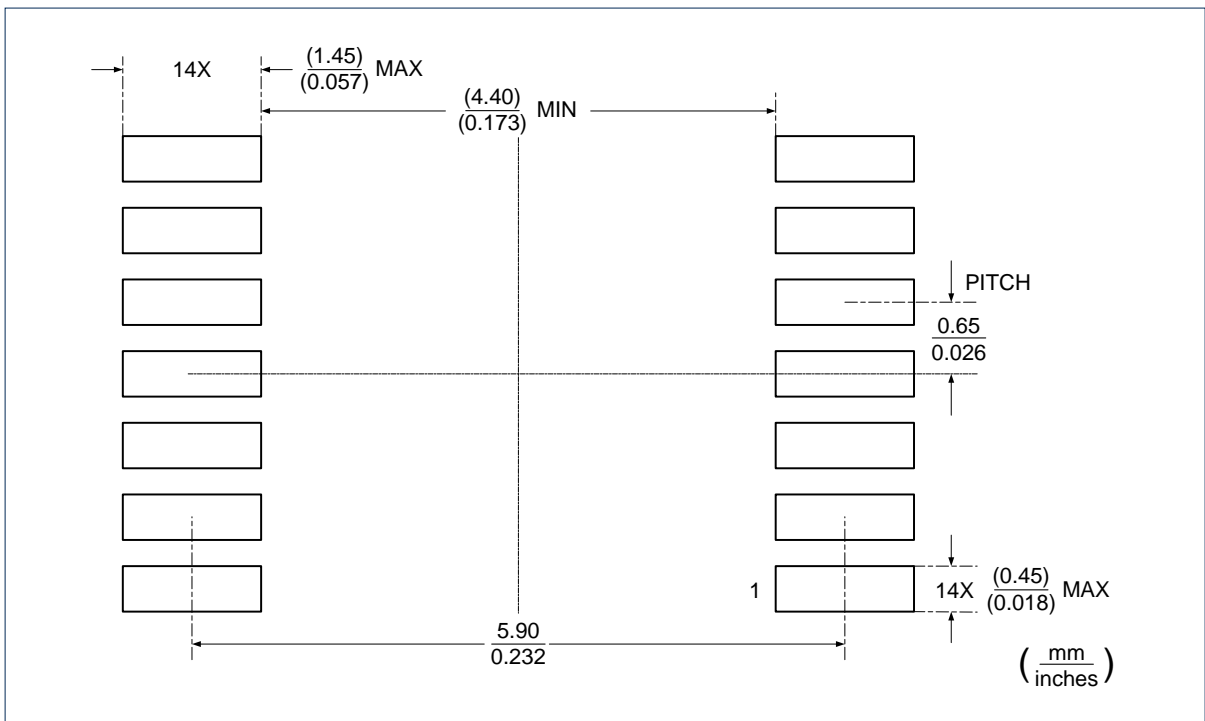

CAUTION: These devices are sensitive to electrostatic discharge; follow proper IC Handling Procedures.
Linearin and designs are registered trademarks of Linearin Technology Corporation.
© Copyright Linearin Technology Corporation. All Rights Reserved.
All other trademarks mentioned are the property of their respective owners.

Important Notice

Linearin is a global fabless semiconductor company specializing in advanced high-performance high-quality analog/mixed-signal IC products and sensor solutions. The company is devoted to the innovation of high performance, analog-intensive sensor front-end products and modular sensor solutions, applied in multi-market of medical & wearable devices, smart home, sensing of IoT, intelligent industrial & smart factory (industrie 4.0), and automotives. Linearin's product families include widely-used standard catalog products, solution-based application specific standard products (ASSPs) and sensor modules that help customers achieve faster time-to-market products. Go to <http://www.linearin.com> for a complete list of Linearin product families.

For additional product information, or full datasheet, please contact with the Linearin's Sales Department or Representatives.