

DESCRIPTION

The LTC5223 is an advanced CMOS analog switch fabricated in Sub-micron silicon gate CMOS technology. The part also features guaranteed Break Before Make (BBM) switching, assuring the switches never short the driver.

FEATURES

- Ultra-Low R_{ON} : 0.55 Ω - Maximum at $V_{CC} = 4.3$ V
- Wide Supply Voltage Range: Single 1.65 V to 5.5 V
- Low Crosstalk
- Full 0 ~ V_{CC} Signal Handling Capability
- High Off - Channel Isolation
- Low Standby Current: 50 nA Maximum
- Low Distortion
- R_{ON} Flatness: 0.15 Ω
- High Continuous Current Capability: ± 300 mA Through Each Switch
- Suitable for Audio Block Switching, Ring-Tone Chips, Amplifier Switching, and Modems, etc.
- ESD : Human Body Model > 4 kV (Reference Document: MIL-STD-883H Method 3015.8)
- Available Packages: QFN1.8x1.4-10L, DFN3x3-10L, and MSOP-10L

PIN CONFIGURATION (Top View)

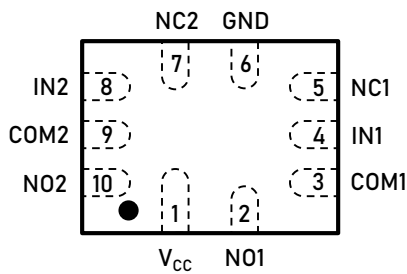

QFN 1.8 X 1.4-10L

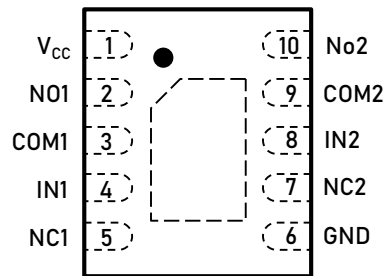

DFN 3 X 3-10L

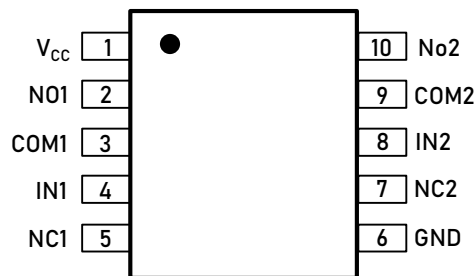

MSOP-10L

ORDER INFORMATION

Model	Package	Ordering Number	Packing Option
LTC5223	QFN1.8×1.4-10L	LTC5223YFS10	Tape and Reel, 3 000
	DFN3×3-10L	LTC5223YF10	Tape and Reel, 3 000
	MSOP-10L	LTC5223YV10	Tape and Reel, 4 000

PIN DESCRIPTIONS

Pin	Symbol	Description
1	V _{CC}	Power Supply
2	N01	Independent Channels
3	COM1	Common Channels
4	IN1	Controls
5	NC1	Independent Channels
6	GND	Ground (V)
7	NC2	Independent Channels
8	IN2	Controls
9	COM2	Common Channels
10	N02	Independent Channels

TRUTH TABLE

IN1, IN2	N01, N02	NC1, NC2
0	OFF	ON
1	ON	OFF

RECOMMENDED OPERATING CONDITIONS

Characteristic	Symbol	Min	Max	Unit	
DC Supply Voltage	V_{CC}	1.65	5.5	V	
Digital Select Input Voltage	V_{IN}	GND	5.5	V	
Analog Input Voltage	V_{IS}	GND	V_{CC}	V	
Operating Temperature Range	T_A	-45	+85	°C	
Input Rise or Fall Time SELECT	t_R, t_F	$V_{CC} = 1.6\text{ V to }2.7\text{ V}$	0	20	ns/V
		$V_{CC} = 3.0\text{ V to }5.5\text{ V}$	0	10	

ABSOLUTE MAXIMUM RATINGS

Characteristic	Symbol	Value	Unit
Supply Voltage	V_{CC}	-0.5 to 6.0	V
Analog Input Voltage	V_{IS}	-0.5 to $V_{CC} + 0.5$	V
Digital Select Input Voltage	V_{IN}	-0.5 to 6.0	V
Output Voltage	V_{OUT}	-0.5 to $V_{CC} + 0.5$	V
Continuous DC Current from COM to NC/NO	I_{an1}	±300	mA
Peak Current from COM to NC/NO, 10 duty cycle (Note 1)	$I_{an1-pk1}$	±500	mA
Continuous DC Current into COM/NO/NC with respect to V_{CC} or GND	I_{clmp}	±100	mA

Stresses beyond those listed under “Absolute Maximum Ratings” may cause permanent damage to the device. These are stress ratings only, and functional operation of the device at these or any other conditions beyond those indicated in the operational sections of the specifications is not implied. Exposure to absolute maximum rating conditions for extended periods may affect device reliability.

Note 1. Defined as 10% ON, 90% off duty cycle.

CAUTION

This integrated circuit can be damaged by ESD if you don't pay attention to ESD protection. Linearin recommends that all integrated circuits be handled with appropriate precautions. Failure to observe proper handling and installation procedures can cause damage. ESD damage can range from subtle performance degradation to complete device failure. Precision integrated circuits may be more susceptible to damage because very small parametric changes could cause the device not to meet its published specifications.

Linearin reserves the right to make any change in circuit design, specification or other related things if necessary without notice at any time. Please contact Linearin sales office to get the latest data sheet.

ELECTRICAL CHARACTERISTICS (DC)

Symbol	Parameter	Test Conditions	$V_{CC} \pm 10\%$	$T_A = 25^\circ\text{C}$			$T_A = -40$ to $+85^\circ\text{C}$		Unit
				Min	Typ	Max	Min	Max	
V_{IH}	High-Level Input Voltage, Select Inputs		1.65 ~ 1.95	1.1			1.1		V
			2.3 ~ 2.5	1.2			1.2		
			2.7 ~ 3.0	1.3			1.3		
			3.0 ~ 3.6	1.4			1.4		
			4.3	1.5			1.5		
V_{IL}	Low-Level Input Voltage, Select Inputs		1.65 ~ 1.95			0.25	0.25		V
			2.3 ~ 2.5			0.25	0.25		
			2.7 ~ 3.0			0.25	0.25		
			3.0 ~ 3.6			0.30	0.30		
			4.3			0.40	0.40		
I_{IN}	Maximum Input Leakage Current, Select Inputs	$V_{IN} = V_{CC}$ or GND	4.3			± 0.1	± 1.0	μA	
I_{OFF}	Power Off Leakage Current	$V_{IN} = V_{CC}$ or GND	0			± 0.5	± 2.0	μA	
I_{CC}	Maximum Quiescent Supply Current (Note 2)	Select, $V_{IS} = V_{CC}$ or GND	1.65 ~ 4.3			± 1.0	± 2.0	μA	
$I_{NO (OFF)}$ $I_{NC (OFF)}$	NC or NO Off Leakage Current	$V_{IN} = V_{IL}$ or V_{IH} V_{NO} or $V_{NC} = 0.3\text{ V}$ $V_{COM} = 4.0\text{ V}$	4.3	-5.0		5.0	-10 10	nA	
COM ON Leakage Current (Note 3)									
$I_{COM (ON)}$	$V_{IN} = V_{IL}$ or V_{IH} , $V_{NO} = 0.3\text{ V}$ or 4.0 V V_{NC} floating $V_{NC} = 0.3\text{ V}$ or 4.0 V V_{NO} floating $V_{COM} = 0.3\text{ V}$ or 4.0 V		4.3	-10		10	-100 100	nA	
R_{ON}	On- Resistance (Note 3)	$V_{IS} = \text{GND to } V_{CC}$, $I_{IN} = 100\text{ mA}$	4.3		0.45	0.5	0.55		Ω
			3.6		0.5	0.55	0.65		
			3.0		0.5	0.55	0.65		
			2.7		0.6	0.7	0.8		
			2.3		0.6	0.7	0.8		
R_{FLAT}	On-Resistance Flatness (Note 3) (Note 5)	$I_{COM} = 100\text{ mA}$ $V_{IS} = 1.5\text{ V}$	4.3		0.15	0.20	0.20		Ω
			3.6		0.15	0.20	0.20		
			3.0		0.15	0.20	0.20		
			2.7		0.15	0.20	0.20		
			2.3		0.20	0.25	0.25		
ΔR_{ON}	On-Resistance Match Between Channels (Note 3) (Note 4)	$I_{COM} = 100\text{ mA}$ $V_{IS} = 1.5\text{ V}$	2.7		0.1			Ω	

ELECTRICAL CHARACTERISTICS (AC)

Symbol	Parameter	Test Conditions	$V_{CC} \pm 10\%$	$T_A = 25^\circ\text{C}$			Unit
				Min	Typ	Max	
tPLH tPHL	Propagation Delay		1.65 ~ 1.95	0.30		ns	
			2.3 ~ 2.7	0.25			
			3.0 ~ 3.3	0.20			
			3.6 ~ 5	0.20			
tON	Turn-On Time (Figure 1)	$V_{IS} = 0.8\text{ V}$	1.65 ~ 1.95	120		ns	
			2.3 ~ 2.7	65	85		
			3.0 ~ 3.3	42	55		
		$V_{IS} = 1.5\text{ V}$	3.6 ~ 4.3	40	55		
			1.65 ~ 1.95	45			
			2.3 ~ 2.7	18	30		
tOFF	Turn-Off Time (Figure 1)	$V_{IS} = 1.5\text{ V}$	3.0 ~ 3.3	16	30	ns	
			3.6 ~ 4.3	15	30		
			1.65 ~ 1.95	2	17		
tBBM	Break-Before-Make Time (Note6)(Figure 2)	$C_L = 35\text{ pF}$ $R_{IS} = 50\ \Omega$ $V_{IS} = 1.5\text{ V}$	2.3 ~ 2.7	2	10	ns	
			3.0 ~ 3.3	2	8		
			3.6 ~ 4.3	2	7		
			1.65 ~ 1.95	18			
BW	On-Channel, -3 dB Bandwidth or Frequency Response (Figure 4)		1.65 ~ 4.3	18	MHz		
	$R_{IS} = 50\ \Omega$						
V_{ISO}	Off-Channel Isolation (Figure 4)						
	$F_{IS} = 100\text{ kHz}$, $V_{IN} = \text{GND to } V_{CC}$, $C_L = 5\text{ pF}$ $R_L = 50\ \Omega$, $V_{IS} = 1V_{RMS}$		1.65 ~ 4.3	-66	dB		
Q	Charge Injection Select Input to Common I/O (Figure 3)		1.65 ~ 1.95	43		pC	
			2.3 ~ 2.7	51			
			3.0 ~ 3.3	51			
			3.6 ~ 4.3	49			
	$V_{IN} = 0\text{ or } V_{CC}$, $R_{IS} = 0\ \Omega$, $C_L = 100\text{ pF}$ $R_L = 1\text{ m}\Omega$, $Q = C_L \times \Delta V_{OUT}$						
THD	Total Harmonic Distortion THD +Noise						
	$F_{IS} = 20\text{ Hz to } 20\text{ kHz}$, $R_L = 600\ \Omega$ $C_L = 50\text{ pF}$, $V_{IS} = 2\text{ VRMS}$		3.0	0.08	%		
V_{CT}	Channel - to - Channel Crosstalk (Figure 4)						
	$F_{IS} = 100\text{ kHz}$, $V_{IN} = \text{GND to } V_{CC}$ $R_L = 50\ \Omega$, $C_L = 5\text{ pF}$, $V_{IS} = 1\text{ VRMS}$		1.65 ~ 4.3	-72	dB		
CIN	Control Pin Input Capacitance		3.6	3.5	pF		
C_{CN}/C_{NO}	NC/NO Port Capacitance		3.6	60	pF		
C_{COM}	COM Port Capacitance When Switch is Enabled		3.6	200	pF		

Note:

- Guaranteed by design.
- Guaranteed by design. Resistance measurements do not include test circuit or package resistance.
- Guaranteed by design. Resistance measurements do not include test circuit or package resistance.
- $\Delta R_{ON} = R_{ON(MAX)} - R_{ON(MIN)}$ between NC1 and NC2 or between NO1 and NO2.
- Flatness is defined as the difference between the maximum and minimum value of on-resistance as measured over the specified analog signal ranges.
- Guaranteed by design in -40°C .

TEST CIRCUITS

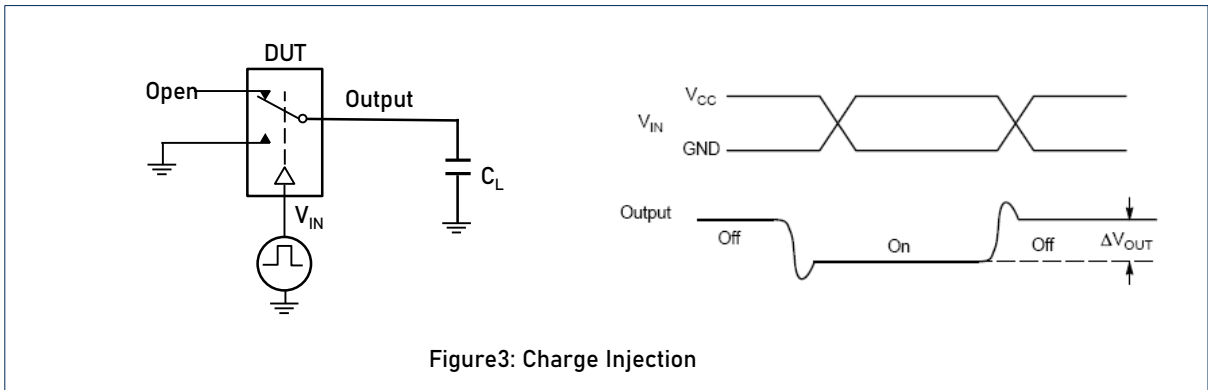
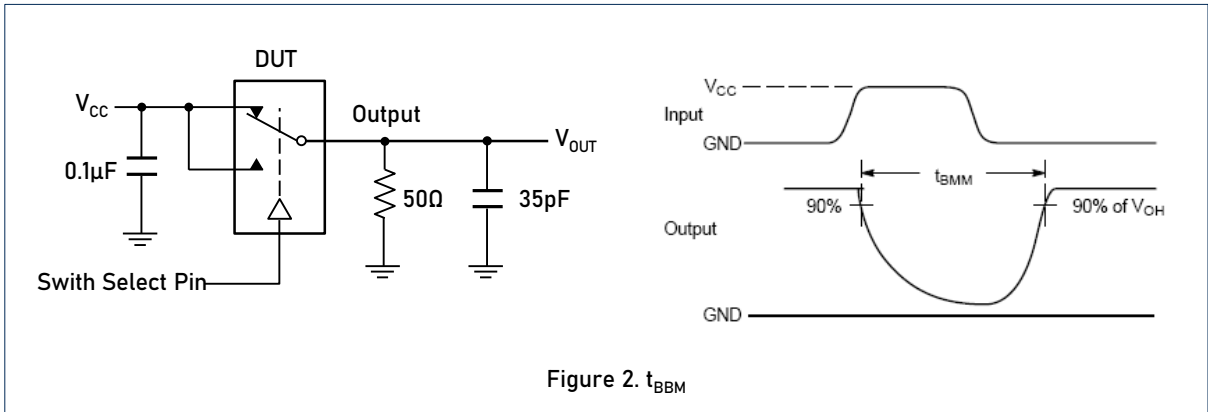
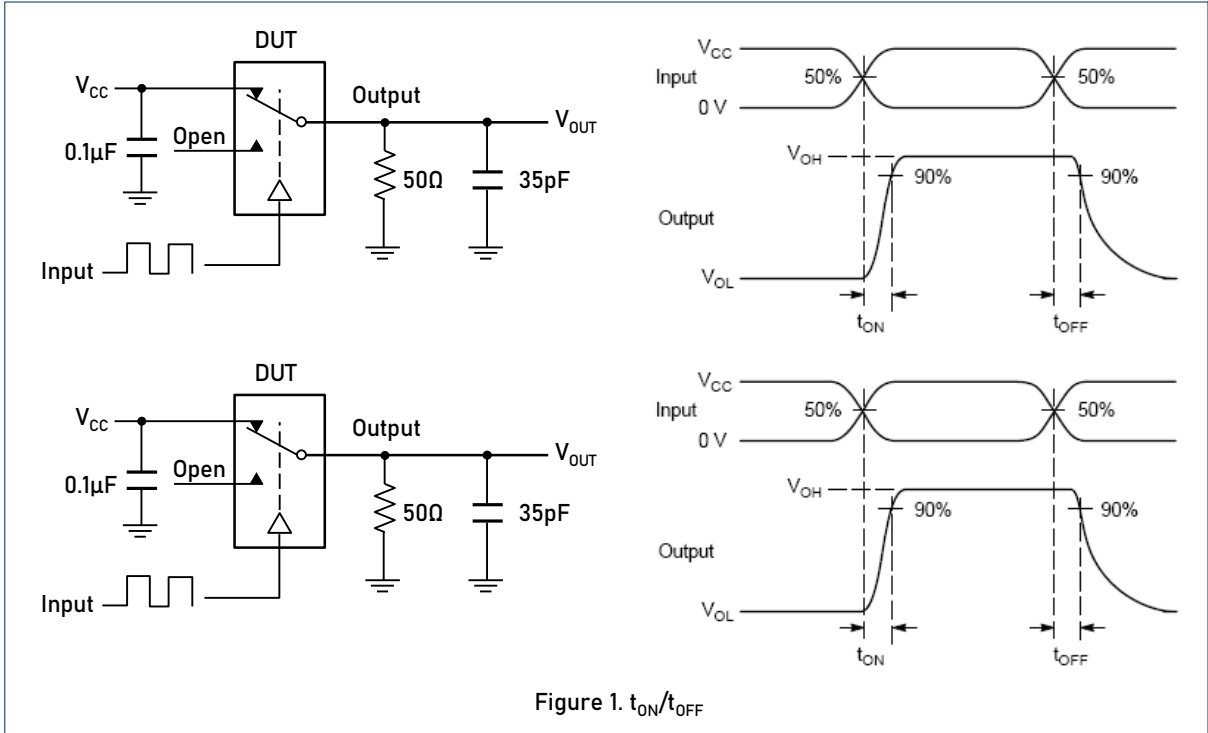

CAUTION: These devices are sensitive to electrostatic discharge; follow proper IC Handling Procedures.
 Linearin and designs are registered trademarks of Linearin Technology Corporation.
 © Copyright Linearin Technology Corporation. All Rights Reserved.
 All other trademarks mentioned are the property of their respective owners.

TEST CIRCUITS (Cont.)

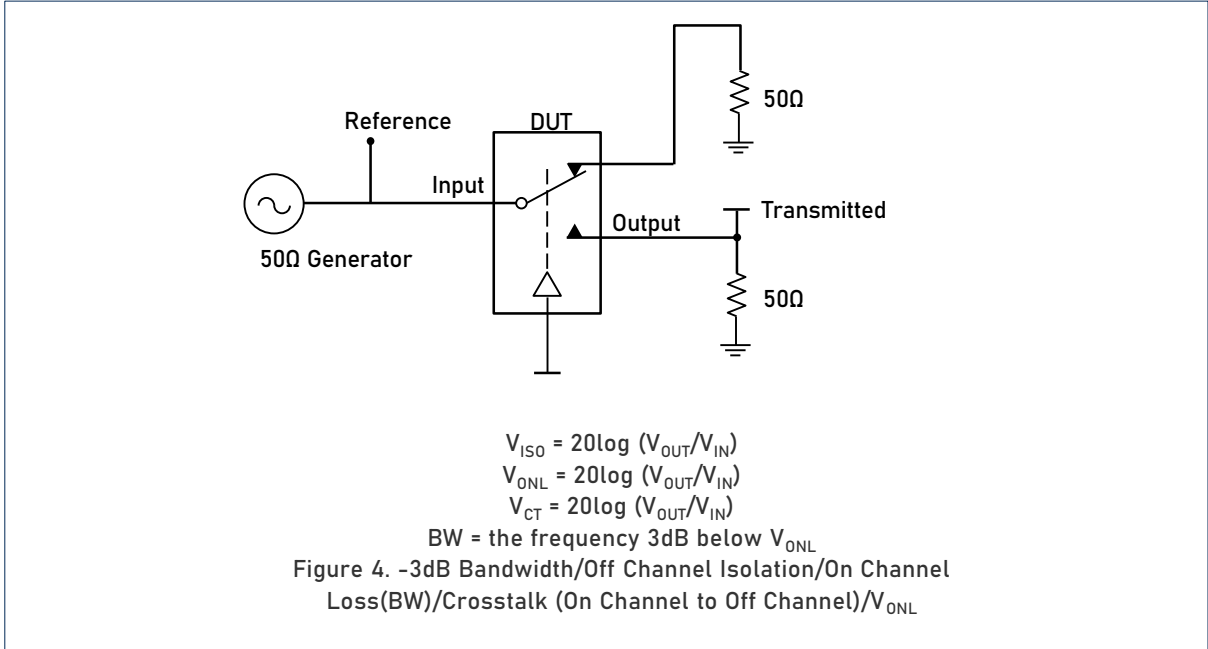

TEST CIRCUITS (Cont.)

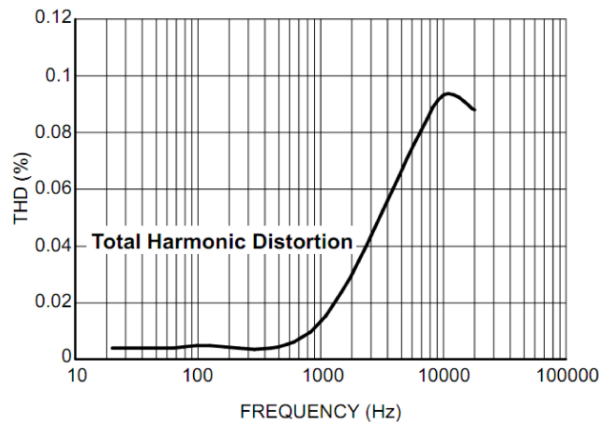
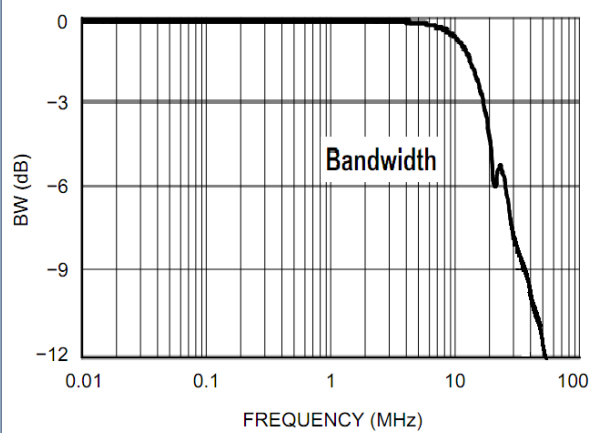
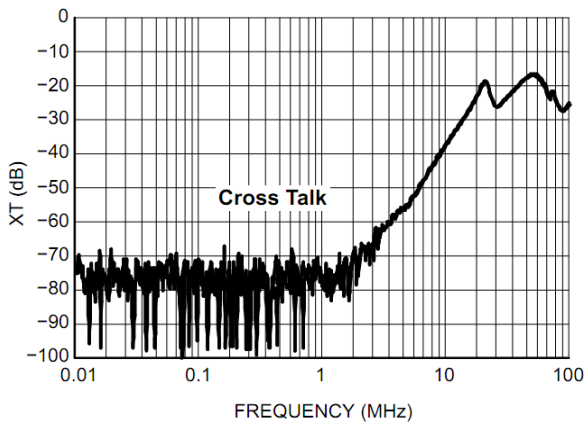

CAUTION: These devices are sensitive to electrostatic discharge; follow proper IC Handling Procedures.
 Linearin and designs are registered trademarks of Linearin Technology Corporation.
 © Copyright Linearin Technology Corporation. All Rights Reserved.
 All other trademarks mentioned are the property of their respective owners.

PACKAGE OUTLINE

QFN1.8×1.4-10L

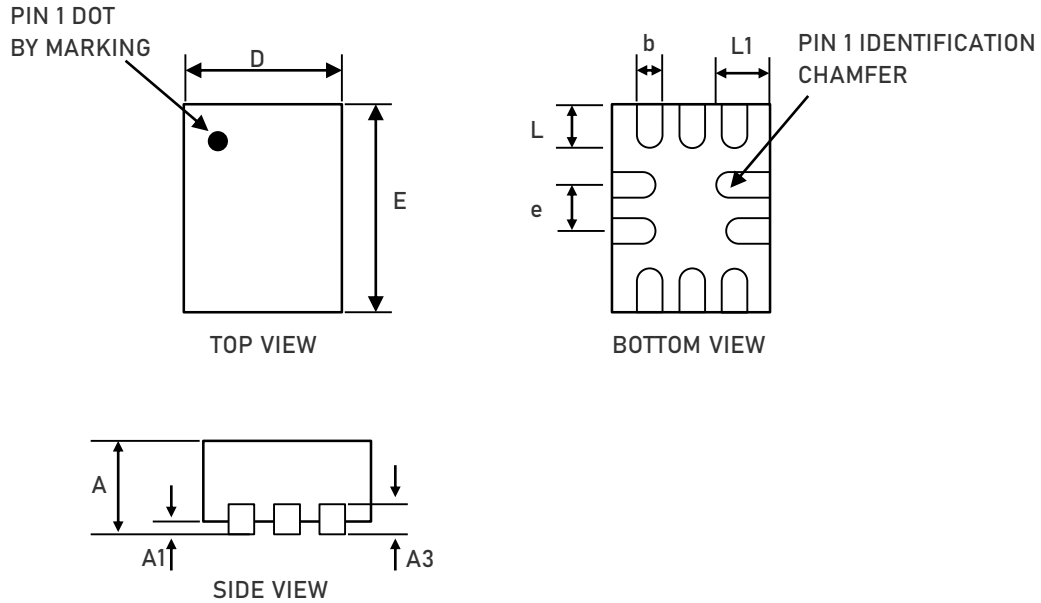

Dimensions In Millimeters (mm)

Symbol	Min.	Nom.	Max.
A	0.500	0.550	0.600
A1	0.000		0.050
A3	0.15 REF		
D	1.350	1.400	1.450
E	1.750	1.800	1.850
b	0.150	0.200	0.250
L	0.300	0.400	0.500
L1	0.400	0.500	0.600
e	0.40 BSC		

PACKAGE OUTLINE

DFN3×3-10L

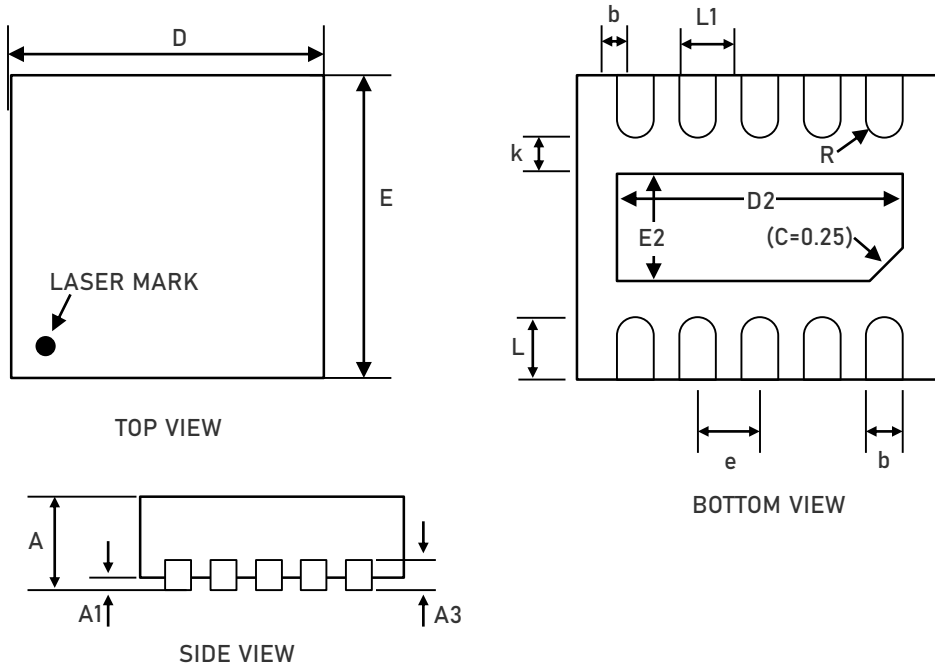

Symbol	Dimensions In Millimeters (mm)	
	Min.	Max.
A	0.700	0.800
A1	0.000	0.050
A3	0.203REF	
b	0.180	0.300
D	2.900	3.100
D2	2.450	2.550
e	0.400	0.600
E	2.900	3.100
E2	1.450	1.650
L	0.350	0.450
k	0.150	
R	0.090	

PACKAGE OUTLINE

MSOP-10L

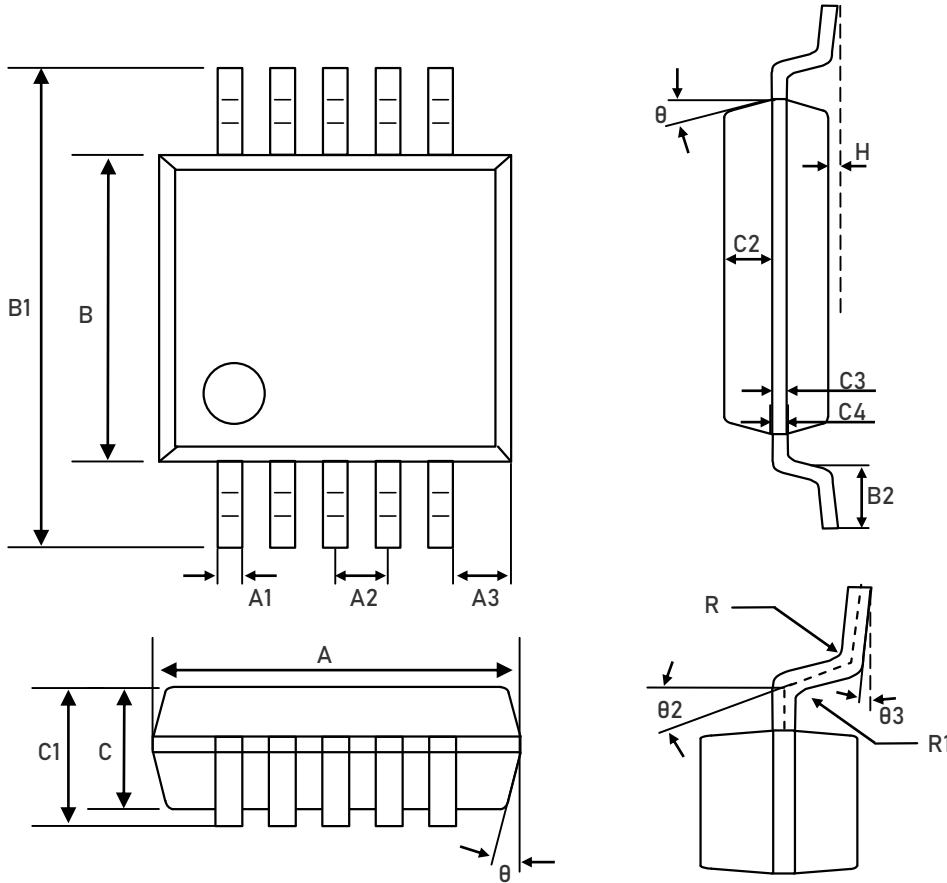

Symbol	Dimensions In Millimeters (mm)	
	Min.	Max.
A	2.900	3.100
A1	0.190	0.280
A2	0.500 TYP	
A3	0.400 TYP	
B	2.900	3.100
B1	4.700	5.100
B2	0.450	0.750
C	0.750	0.950
C1		1.100
C2	0.328 TYP	

CAUTION: These devices are sensitive to electrostatic discharge; follow proper IC Handling Procedures.
 Linearin and designs are registered trademarks of Linearin Technology Corporation.
 © Copyright Linearin Technology Corporation. All Rights Reserved.
 All other trademarks mentioned are the property of their respective owners.