

## 1. General Description

The LTP8036 is a series of multifunctional microprocessor supervisory circuit that monitors supply voltage rails from 0.4 V to 5 V. When the voltage on SENSE pin drops below the factory-preset threshold, or the manual reset pin ( $\overline{\text{MR}}$ ) switches to logic low, the device asserts an open-drain  $\overline{\text{RESET}}$  output signal. Only when the both trigger conditions are removed, the output  $\overline{\text{RESET}}$  recovers after a user-defined delay time.

The LTP8036 employs a high-precision internal bandgap voltage reference to provide 1% threshold accuracy for all threshold voltage versions. The reset delay time is adjustable by changing the setup of the connection of  $C_T$  pin. The delay time can be set to 20 ms by floating the  $C_T$ , or 300 ms by connecting  $C_T$  to  $V_{DD}$  through a resistor, or vary from 1.25 ms to 10 s by adjusting the external capacitor connected to  $C_T$ . The device features an ultra-low-power consumption. A quiescent current as low as 0.6  $\mu\text{A}$  makes the device suitable for any power sensitive applications, for example battery-powered devices. It is available in SOT23-6L and DFN2 $\times$ 2-6L packages and is fully specified over a temperature range of  $-40^\circ\text{C}$  to  $125^\circ\text{C}$ .

## 2. Features and Benefits

- Adjustable delay time: 1.25 ms to 10 s.
- Ultra-low quiescent current: 0.6  $\mu\text{A}$  typical
- High threshold accuracy: 1%
- Fixed threshold voltages for standard voltage rails from 0.9 V to 5 V or adjustable voltage down to 0.4V
- Manual reset input:  $\overline{\text{MR}}$
- Open-drain output:  $\overline{\text{RESET}}$
- Small packages: available in SOT23-6L and DFN2 $\times$ 2-6L
- Temperature range:  $-40^\circ\text{C}$  to  $125^\circ\text{C}$

## 3. Applications

- Microprocessor or micro-controller applications
- Personal computers
- Battery-powered products
- Portable and hand-held products
- FPGA and ASIC applications

## 4. Pin Configuration (Top View)

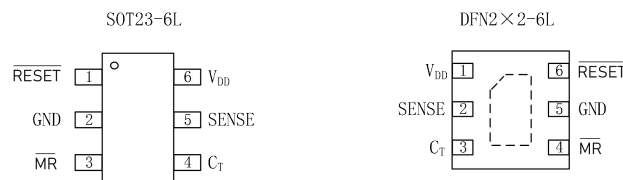

## Table of Contents

1. General Description .....	1	13.2. Feature Description .....	7
2. Features and Benefits .....	1	13.2.1. Sense Input .....	7
3. Applications .....	1	13.2.2. Reset Delay Time .....	8
4. Pin Configuration (Top View) .....	1	13.2.3. Manual Reset Input .....	8
5. Device Versions and Thresholds .....	3	13.2.4. Reset Output .....	9
6. Pin Description .....	3	13.3. Power-On Reset Function .....	9
7. Typical Applications Diagram .....	3	13.3.1. Normal Operation .....	9
8. Ordering Information .....	4	13.3.2. Above Power-On Reset Voltage but below $V_{DD(min)}$ .....	9
9. Limiting Value .....	4	13.3.3. Below Power-On Reset Voltage .....	9
10. ESD Ratings .....	4	14. Package Outlines .....	10
11. Electrical Characteristics .....	5	SOT23-6L .....	10
12. Typical Characteristics .....	6	DFN2*2-6L .....	11
13. Detailed Description .....	7		
13.1. Functional Block Diagram .....	7		

## List of Figures

Fig.1 Dual supply rails simultaneously monitoring .....	3
Fig.2 Supply Current $I_{DD}$ vs. Supply Voltage $V_{DD}$ .....	6
Fig.3 External Capacitance $C_T$ vs. Recovery Delay Time .....	6
Fig.4 Normalized Delay Time vs. Ambient Temperature .....	6
Fig.5 Transient Duration vs. Overdrive .....	6
Fig.6 Normalized Threshold vs. Ambient Temperature .....	6
Fig.7 Low-level $\overline{RESET}$ Voltage vs. $\overline{RESET}$ Current under Different Supply Voltage .....	6
Fig.8 Functional block diagram .....	7
Fig.9 Adjustable threshold set by external resistor divider using LTP8036-01 .....	8
Fig.10 Delay time configuration .....	8
Fig.11 Use a MOSFET to deal with driving voltage mismatch .....	9

## 5. Device Versions and Thresholds

Version	Nominal Supply Voltage	Threshold voltage
LTP8036-01	Adjustable by external resistor divider	0.405 V
LTP8036-09	0.9 V	0.84 V
LTP8036-12	1.2 V	1.12 V
LTP8036-125	1.25 V	1.16 V
LTP8036-15	1.5 V	1.40 V
LTP8036-18	1.8 V	1.67 V
LTP8036-19	1.9 V	1.77 V
LTP8036-25	2.5 V	2.33 V
LTP8036-30	3 V	2.79 V
LTP8036-33	3.3 V	3.07 V
LTP8036-50	5 V	4.65 V

## 6. Pin Description

Symbol	Pin Number		Description
	SOT23-6L	DNF2×2-6L	
$C_T$	4	3	Delay time programming pin. Detailed information is given in section 13.2.2.
GND	2	5	Ground pin.
$\overline{MR}$	3	4	Manual reset pin. By driving $\overline{MR}$ low, $\overline{RESET}$ is asserted. $\overline{MR}$ is internally tied to $V_{DD}$ through a pull-up resistor.
$\overline{RESET}$	1	6	Open-drain output pin. $\overline{RESET}$ remains to be logic low for user defined delay period after SENSE voltage recovers to be above $V_{IT}$ and $\overline{MR}$ is set to logic high. $\overline{RESET}$ pin requires an external 10 k $\Omega$ to 1 M $\Omega$ pull-up resistor to supply voltage which is allowed to be higher than $V_{DD}$ .
SENSE	5	2	Input pin connected to the voltage expected to be monitored. Once the voltage drops below the preset threshold voltage $V_{IT}$ , the $\overline{RESET}$ is asserted.
$V_{DD}$	6	1	Supply voltage pin. It is recommended to place a 0.1 $\mu$ F ceramic capacitor as close as possible to this pin.
Thermal Pad	NA	Thermal Pad	Thermal pad. Connect to ground plane for enhanced thermal performance.

## 7. Typical Applications Diagram

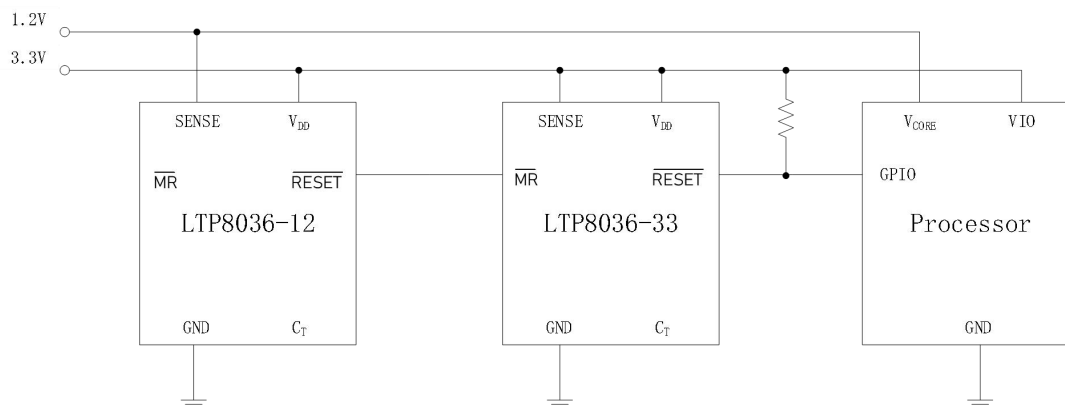

Fig.1 Dual supply rails simultaneously monitoring

## 8. Ordering Information

Part Number	Package Type	Quantity	Mark Code
LTP8036-01XT6/R6	SOT23-6L	Tape and Reel, 3000	3601
LTP8036-01XF6/R6	DFN2×2-6L	Tape and Reel, 3000	3601
LTP8036-09XT6/R6	SOT23-6L	Tape and Reel, 3000	3609
LTP8036-09XF6/R6	DFN2×2-6L	Tape and Reel, 3000	3609
LTP8036-12XT6/R6	SOT23-6L	Tape and Reel, 3000	3612
LTP8036-12XF6/R6	DFN2×2-6L	Tape and Reel, 3000	3612
LTP8036-125XT6/R6	SOT23-6L	Tape and Reel, 3000	3613
LTP8036-125XF6/R6	DFN2×2-6L	Tape and Reel, 3000	3613
LTP8036-15XT6/R6	SOT23-6L	Tape and Reel, 3000	3615
LTP8036-15XF6/R6	DFN2×2-6L	Tape and Reel, 3000	3615
LTP8036-18XT6/R6	SOT23-6L	Tape and Reel, 3000	3618
LTP8036-18XF6/R6	DFN2×2-6L	Tape and Reel, 3000	3618
LTP8036-19XT6/R6	SOT23-6L	Tape and Reel, 3000	3619
LTP8036-19XF6/R6	DFN2×2-6L	Tape and Reel, 3000	3619
LTP8036-25XT6/R6	SOT23-6L	Tape and Reel, 3000	3625
LTP8036-25XF6/R6	DFN2×2-6L	Tape and Reel, 3000	3625
LTP8036-30XT6/R6	SOT23-6L	Tape and Reel, 3000	3630
LTP8036-30XF6/R6	DFN2×2-6L	Tape and Reel, 3000	3630
LTP8036-33XT6/R6	SOT23-6L	Tape and Reel, 3000	3633
LTP8036-33XF6/R6	DFN2×2-6L	Tape and Reel, 3000	3633
LTP8036-50XT6/R6	SOT23-6L	Tape and Reel, 3000	3650
LTP8036-50XF6/R6	DFN2×2-6L	Tape and Reel, 3000	3650

## 9. Limiting Value

Parameter	MIN	MAX	UNIT
$V_{DD}$ , $V_{RESET}$ , $V_{NR}$ , $V_{SENSE}$	-0.3	7	V
$V_{CT}$	-0.3	$V_{DD}+0.3$	V
$I_{RESET}$	-5	5	mA
$T_J$	-40	150	°C
$T_{STG}$	-65	150	°C

## 10. ESD Ratings

Parameter	Level	UNIT
Human body model (HBM), per ANSI/ESDA/JEDEC JS-001, all pins	±4000	V
Charged device model (CDM), per JEDEC specification JESD22-C101, all pins	±1000	V

## 11. Electrical Characteristics

1.65 V ≤ V<sub>DD</sub> ≤ 6.5 V, R<sub>LRESET</sub> = 100 kΩ, C<sub>LRESET</sub> = 50 pF, over operating temperature range (T<sub>J</sub> = -40°C to 125°C), unless otherwise noted. Typical values are at T<sub>J</sub> = 25°C.

Parameter	Conditions	Min	Typ	Max	Unit
V <sub>DD</sub> , Input supply range	-40 °C ≤ T <sub>J</sub> ≤ 125 °C	1.65		6.5	V
I <sub>DD</sub> Supply current	V <sub>DD</sub> = 3.3 V, $\overline{\text{RESET}}$ not asserted, $\overline{\text{MR}}$ , $\overline{\text{RESET}}$ , and CT open		0.6	1.2	μA
	V <sub>DD</sub> = 6.5 V $\overline{\text{RESET}}$ not asserted, $\overline{\text{MR}}$ , $\overline{\text{RESET}}$ , and C <sub>T</sub> open		0.95	1.9	
V <sub>OL</sub> Low-level output voltage	1.3 V ≤ V <sub>DD</sub> ≤ 1.8 V, I <sub>OL</sub> = 0.4 mA			0.15	V
	1.8 V ≤ V <sub>DD</sub> ≤ 6.5 V, I <sub>OL</sub> = 1 mA			0.2	
V <sub>POR</sub> Power-up reset voltage	V <sub>OL(max)</sub> = 0.2 V, I <sub>RESET</sub> = 15 μA			0.8	V
V <sub>IT</sub> Negative-going input threshold accuracy	All version, T <sub>A</sub> = 25 °C	-1		1	%
	V <sub>IT</sub> ≤ 3.3 V	-1.5		1.5	
	3.3 V ≤ V <sub>IT</sub> ≤ 5 V	-1.8		1.8	
V <sub>HYS</sub> Hysteresis on V <sub>IT</sub>	All versions			3.5	%
R <sub>MR</sub> $\overline{\text{MR}}$ internal pull-up resistance		80	100		kΩ
I <sub>SENSE</sub> Input current at SENSE pin	LTP8036-01, V <sub>SENSE</sub> = V <sub>IT</sub>	-10		10	nA
	The other versions, V <sub>SENSE</sub> = 6.5 V		235		nA
I <sub>OH</sub> $\overline{\text{RESET}}$ leakage current	V <sub>RESET</sub> = 6.5V, $\overline{\text{RESET}}$ not asserted			0.1	μA
C <sub>IN</sub> Input capacitance, any pin	C <sub>T</sub> pin, V <sub>IN</sub> = 0 V to 6.5 V		5		pF
	The other pins, V <sub>IN</sub> = 0 V to 6.5 V		5		
V <sub>IL</sub> $\overline{\text{MR}}$ input logic low	Version A <sup>(1)</sup>	0		0.1V <sub>DD</sub>	V
	Version B <sup>(1)</sup>	0		0.3V <sub>DD</sub>	
V <sub>IH</sub> $\overline{\text{MR}}$ input logic high	Version A <sup>(1)</sup>	0.9V <sub>DD</sub>		V <sub>DD</sub>	V
	Version B <sup>(1)</sup>	0.7V <sub>DD</sub>		V <sub>DD</sub>	
t <sub>SENSE</sub> Input pulse width to $\overline{\text{RESET}}$	V <sub>IH</sub> = 1.05V <sub>IT</sub> , V <sub>IL</sub> = 0.95V <sub>IT</sub>		65		μs
t <sub>MR</sub> Input pulse width to $\overline{\text{RESET}}$	V <sub>IH</sub> = 0.7V <sub>IT</sub> , V <sub>IL</sub> = 0.3V <sub>IT</sub>		85		ns
V <sub>TH-RAMP</sub> C <sub>T</sub> source threshold voltage			1.22		V
t <sub>D</sub> $\overline{\text{RESET}}$ delay time	C <sub>T</sub> floating		20		ms
	C <sub>T</sub> = V <sub>DD</sub>		300		ms
	C <sub>T</sub> = 100 pF		1.1		ms
t <sub>MR</sub> Propagation delay	$\overline{\text{MR}}$ to $\overline{\text{RESET}}$		70		ns
t <sub>PRO</sub> High-to-low level $\overline{\text{RESET}}$ delay	SENSE to $\overline{\text{RESET}}$		55		μs

(1) Two versions are available for the nMR input V<sub>IH</sub> and V<sub>IL</sub> voltage levels. Customers with specific requirements regarding these voltages are advised to contact Linearin for confirmation before proceeding with your order.

## 12. Typical Characteristics

$T_J = +25\text{ }^\circ\text{C}$ ,  $V_{DD} = 3.3\text{ V}$  and  $R_{LRESET} = 100\text{ k}\Omega$ , unless otherwise noted.

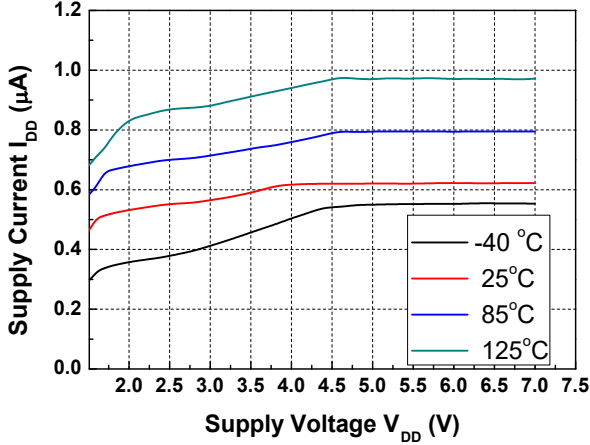

Fig.2 Supply Current  $I_{DD}$  vs. Supply Voltage  $V_{DD}$

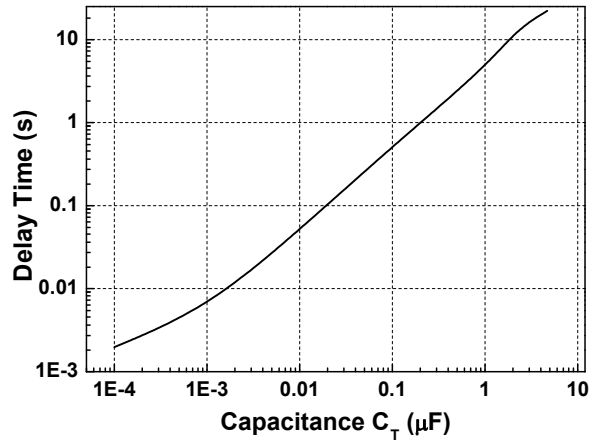

Fig.3 External Capacitance  $C_T$  vs. Recovery Delay Time

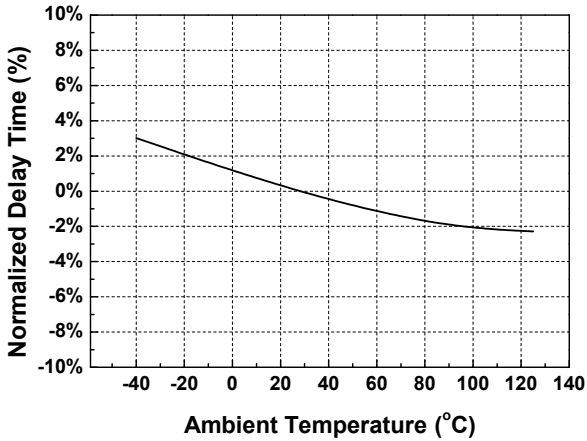

Fig.4 Normalized Delay Time vs. Ambient Temperature

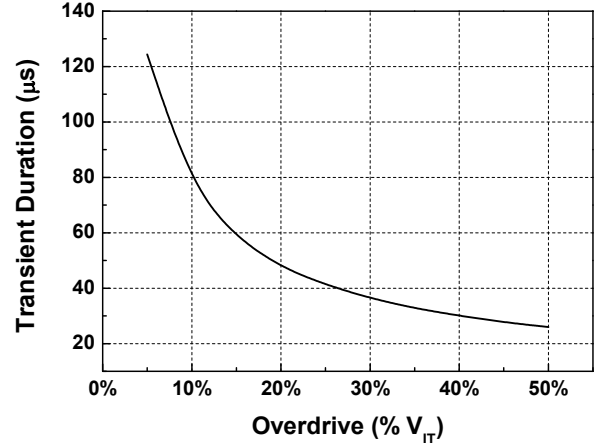

Fig.5 Transient Duration vs. Overdrive

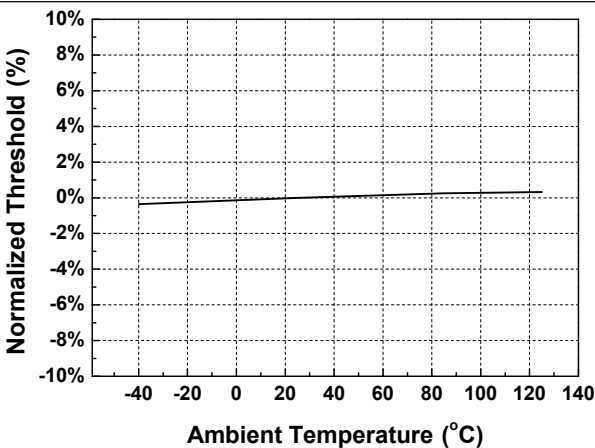

Fig.6 Normalized Threshold vs. Ambient Temperature

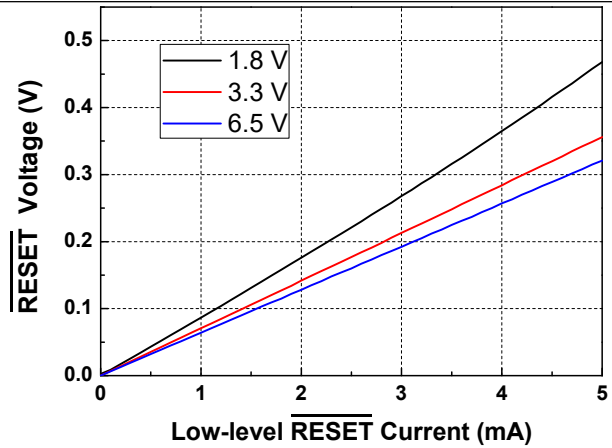

Fig.7 Low-level  $\overline{\text{RESET}}$  Voltage vs.  $\overline{\text{RESET}}$  Current under Different Supply Voltage

## 13. Detailed Description

### 13.1. Functional Block Diagram

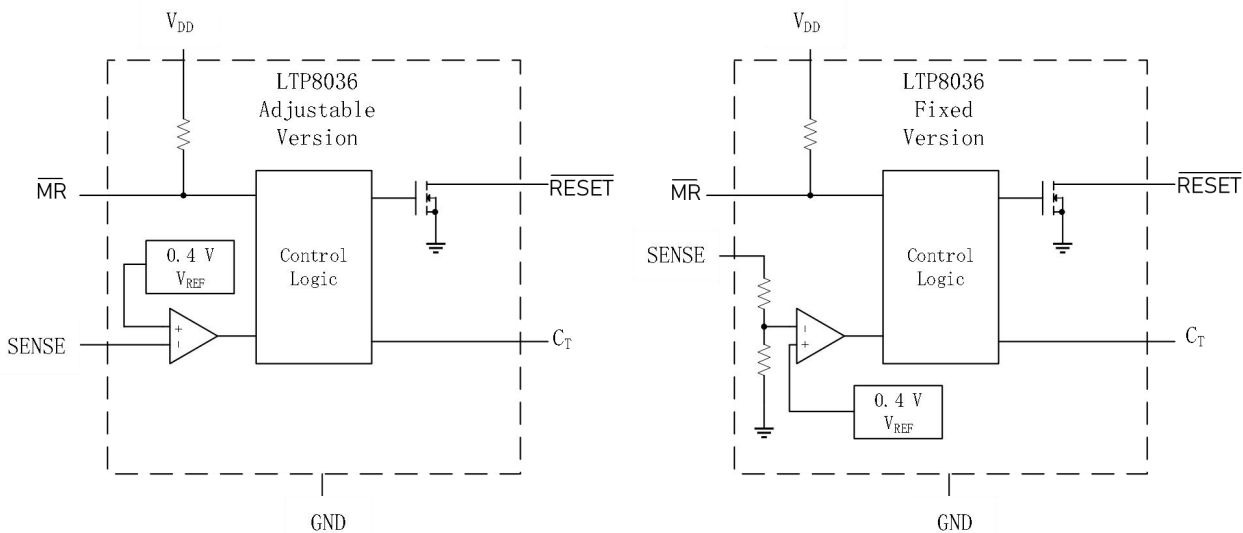

Fig.8 Functional block diagram

### 13.2. Feature Description

The LTP8036 series provide options of a wide range of monitoring voltage threshold and reset delay time. Such property makes it suitable for various applications. Fixed threshold voltage versions could cover from 0.9 V up to 5 V as the supply voltage being monitored. The threshold voltage of adjustable version can be set to any voltage above 0.405V by external resistor divider. Users can select from two preset reset delay time: 20 ms by floating  $C_T$  pin and 300 ms by connecting  $C_T$  pin to  $V_{DD}$  through resistor, or users can choose any delay time between 1.25 ms to 10 s by varying the capacitance of external capacitor between  $C_T$  and ground

#### 13.2.1. Sense Input

SENSE pin senses the input voltage to be monitored, and will assert  $\overline{RESET}$  if the voltage being sensed drops below the threshold. A built-in hysteresis of the comparator avoids uncertainty near the threshold value. It is recommended to place a 1 nF to 10 nF bypass capacitor on the SENSE pin to reduce transients and layout parasitics. The SENSE pin can endure short negative transients, and the endurable time is related to the threshold overdrive as shown in Fig.5. The adjustable version LTP8301 can set the threshold voltage to any value above 0.405 V using circuit shown below.

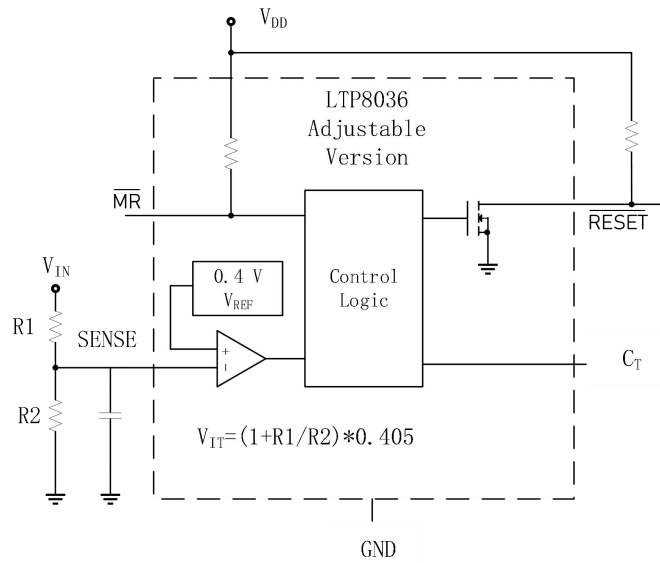

Fig.9 Adjustable threshold set by external resistor divider using LTP8036-01

### 13.2.2. Reset Delay Time

The reset delay time of the device can be selected from two fixed values or configured by varying the capacitance value connected to C<sub>T</sub> pin. By floating C<sub>T</sub>, a fixed 20 ms delay time is set. By connecting the C<sub>T</sub> to V<sub>DD</sub> through a resistor, from 40 kΩ to 200 kΩ, a fixed 300 ms delay time is set. User defined delay time between 1.25 ms to 10 s can be programmed by an external ground-referenced capacitor.

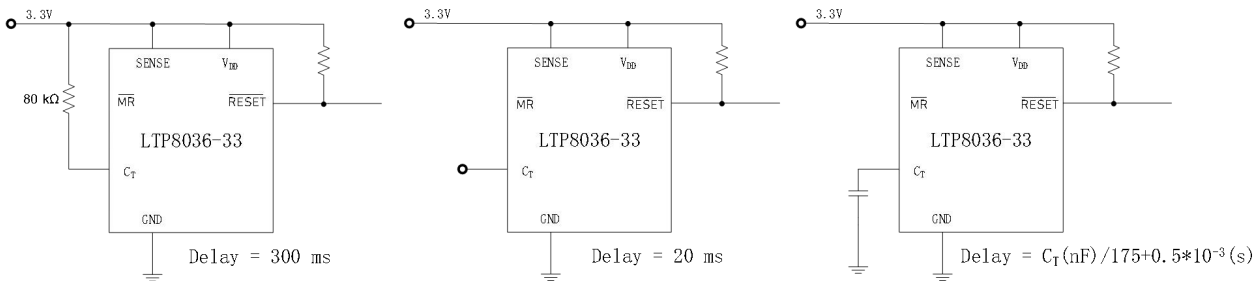

Fig.10 Delay time configuration

The reset delay time is determined by the charging time of a precise internal 220 nA current source to charge the external capacitor to 1.23 V. It follows the relations shown as below:

$$T_D = C_T(\text{nF}) / 175 + 0.5 * 10^{-3} (\text{s})$$

When reset condition is triggered either by SENSE pin or manual reset pin, the capacitor discharges. When the conditions are removed, the current source starts to charge the capacitor until its voltage reaches 1.23 V, and therefore deassert the status of  $\overline{\text{RESET}}$ . In order to have a smaller error in reset delay time, it recommended to use low-leakage ceramic capacitor.

### 13.2.3. Manual Reset Input

The manual reset input provides an active way to trigger a reset, by switching  $\overline{\text{MR}}$  to logic low. This pin is internally pulled up through a resistor to V<sub>DD</sub>, so this pin can be left floated. It is recommended to use a MOSFET to minimize drawing current in case the driving voltage on  $\overline{\text{MR}}$  does not match with V<sub>DD</sub>.

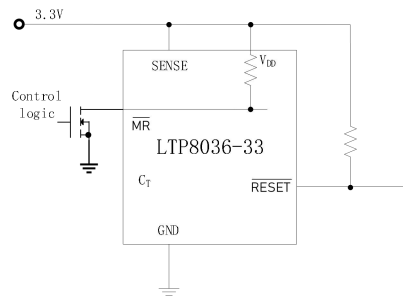

Fig.11 Use a MOSFET to deal with driving voltage mismatch

### 13.2.4. Reset Output

Either condition which is voltage to be monitored dropping below threshold or  $\overline{\text{MR}}$  switching to logic low, will assert the reset output, driving the  $\overline{\text{RESET}}$  pin to a low impedance. After both conditions are removed, the delay circuit starts up to provide a user-defined delay time. The external pull-up resistor help to get a voltage higher than  $V_{\text{DD}}$ .

### 13.3. Power-On Reset Function

Depending on power supply condition, the device works in three modes, explained as following:

#### 13.3.1. Normal Operation

When supply voltage  $V_{\text{DD}}$  meets the basic requirements to make the circuits work, i.e. greater than  $V_{\text{DD}(\text{min})}$ , the output  $\overline{\text{RESET}}$  behaves according to voltage on the SENSE pin and the logic state of  $\overline{\text{MR}}$  as introduced in previous sessions.

#### 13.3.2. Above Power-On Reset Voltage but below $V_{\text{DD}(\text{min})}$

When the supply voltage is above power-on reset voltage  $V_{\text{POR}}$  but below  $V_{\text{DD}(\text{min})}$ , the  $\overline{\text{RESET}}$  remains asserted and low impedance no matter what state of voltage is on SENSE pin and  $\overline{\text{MR}}$ .

#### 13.3.3. Below Power-On Reset Voltage

When the supply voltage is below  $V_{\text{POR}}$ ,  $\overline{\text{RESET}}$  is not defined.

## 14. Package Outlines

## SOT23-6L

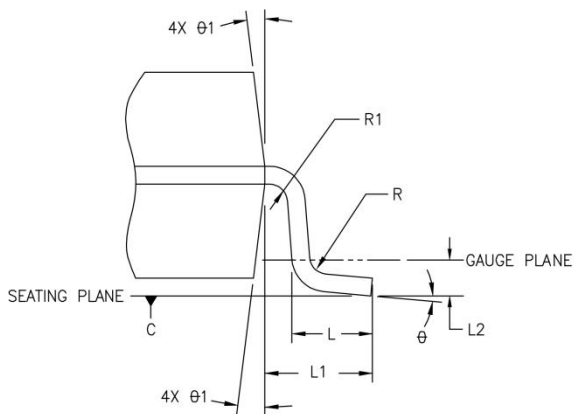
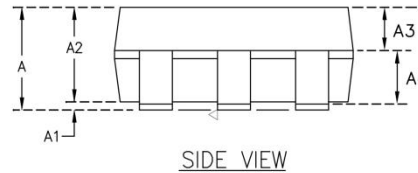
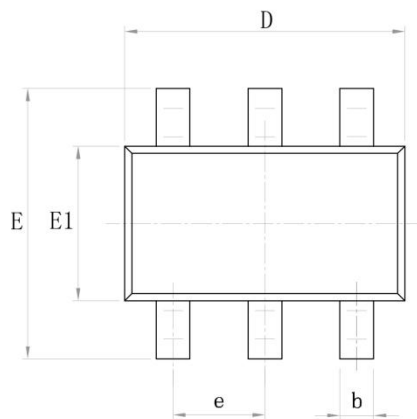

Symbol	尺寸(mm)		
	Min.	Nom.	Max.
A	1.00	---	1.35
A1	0.00	---	0.15
A2	1.00	1.10	1.20
A3	0.349	0.399	0.449
A4	0.511	---	0.701
b	0.35	---	0.45
D	2.82	2.92	3.02
E	2.60	2.80	3.00
E1	1.526	1.626	1.726
e	0.90	0.95	1.00
L	0.35	0.45	0.60
L1	0.60 REF		
L2	0.25 REF		
R	0.10	---	---
R1	0.10	---	0.25
$\theta$	0°	4°	8°
$\theta_1$	5°	10°	15°

## DFN2\*2-6L

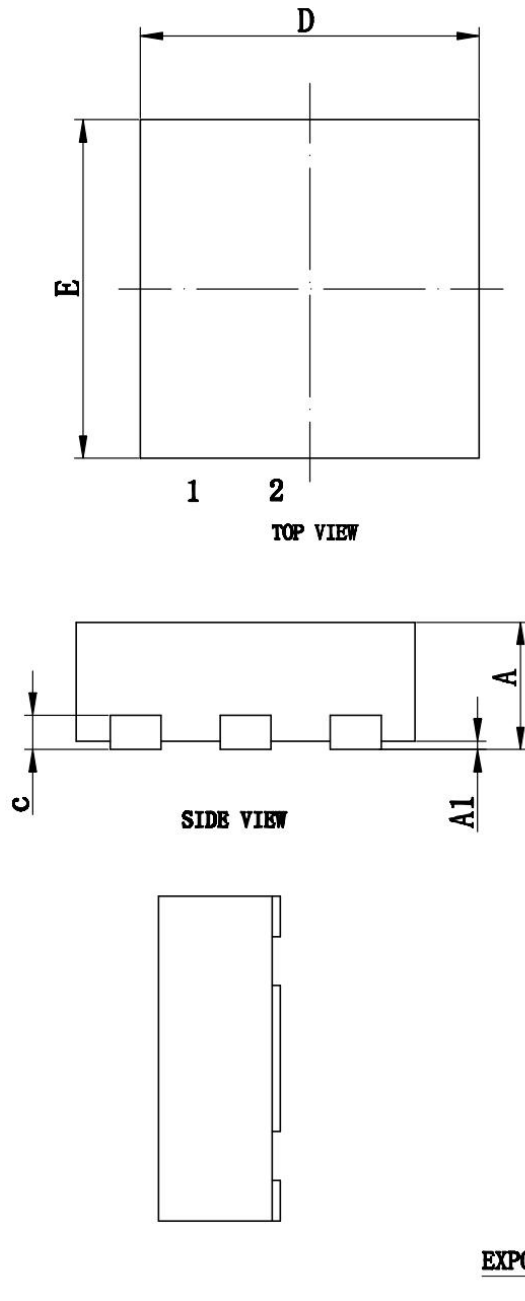

Symbol	尺寸(mm)		
	Min.	Nom.	Max.
A	0.70	0.75	0.80
A1	---	0.02	0.05
b	0.25	0.30	0.35
c	0.18	0.20	0.25
D	1.90	2.00	2.10
D2	1.50	1.60	1.70
e	0.65 BSC		
Nd	1.30 BSC		
E	1.90	2.00	2.10
E2	0.90	1.00	1.10
K	0.20	---	---
L	0.20	0.25	0.30
L1	0.15	0.20	0.25

