

## General Description

The LTA6371, LTA6372 and LTA6374 are a family of micro-power, 36V wide supply voltage, rail-to-rail input and output operational amplifiers capable of operating on supplies ranging from +4V to +36V. LTA6371/LTA6372/LTA6374 offer outstanding dc precision and ac performance, including low offset (1.5mV typically), low offset drift (5  $\mu$ V/°C typically), 6MHz bandwidth, Unique features such as differential input-voltage range to the negative supply rail, Short-circuit current (35mA), high capacitive load drive of up to 1nF, and high slew rate (10V/ $\mu$ s) make the LTA6371/LTA6372/LTA6374 high-performance operational amplifiers for high-voltage industrial applications.

The robust design of the LTA6371/LTA6372/LTA6374 family provides ease-of-use to the circuit designer: integrated RF/EMI rejection filter, no phase reversal in overdrive conditions, and high electro-static discharge (ESD) protection. The LTA6371/LTA6372/LTA6374 are optimized for operation at voltages from +4V ( $\pm$ 2V) to +36V ( $\pm$ 18V) over the extended temperature range of  $-40^{\circ}\text{C}$  to  $+125^{\circ}\text{C}$ .

## Features and Benefits

- Supply Voltage: 4V to 36V
- Offset Voltage: 5mV
- Differential Input Voltage Range to Supply Rail, can Work as Comparator
- Rail-to-Rail Input and Output
- Bandwidth: 6MHz
- Slew Rate: 10V/ $\mu$ s
- Operation Temperature Range:  $-40^{\circ}\text{C}$  to  $125^{\circ}\text{C}$

## Applications

- Instrumentation
- Sensor Interface
- Motor Control
- Industrial Control
- Audio

Table of Content

General Description.....	1
Features and Benefits .....	1
Applications.....	1
Table of Content.....	2
Pin Configuration (Top View) .....	3
Pin Description.....	3
Ordering Information <sup>(1)</sup> .....	3
Limiting Value.....	4
ESD Ratings.....	4
Thermal Information.....	4
Electrical Characteristics .....	5
Typical Characteristics .....	7
Tape and Reel Information .....	9
Package Outlines.....	10
Important Notice.....	16

### Pin Configuration (Top View)

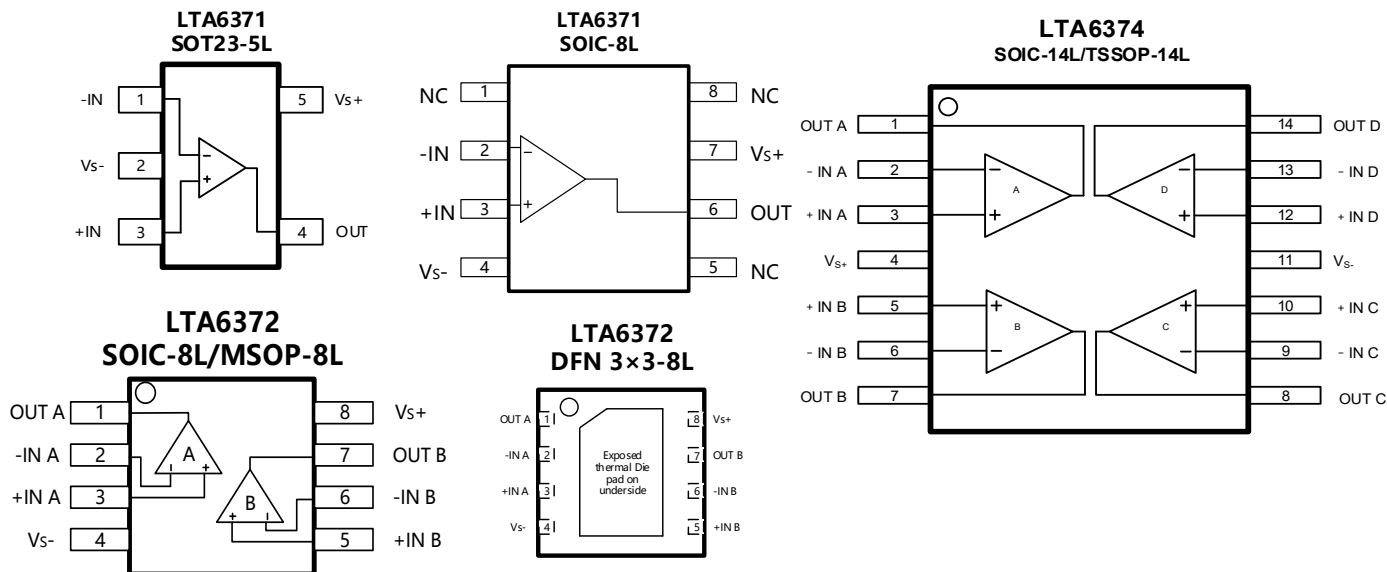

### Pin Description

PIN Name	Description
OUT	Output.
-IN	Inverting input.
+IN	Non-inverting input.
V <sub>s-</sub>	Negative power supply.
V <sub>s+</sub>	Positive power supply.
NC	No connection.

### Ordering Information<sup>(1)</sup>

Part Number	Package Type	Package Quantity	ECO Class <sup>(2)</sup>	Mark Code <sup>(3)</sup>
LTA6371XT5/R6	SOT23-5L	Tape and Reel, 3 000	Green (RoHS & no Sb/Br)	F71
LTA6371XS8/R8	SOIC-8L	Tape and Reel, 4 000	Green (RoHS & no Sb/Br)	F6371
LTA6372XS8/R8	SOIC-8L	Tape and Reel, 4 000	Green (RoHS & no Sb/Br)	F6372
LTA6372XV8/R6	MSOP-8L	Tape and Reel, 3 000	Green (RoHS & no Sb/Br)	F6372
LTA6372XF8/R6	DFN3x3-8L	Tape and Reel, 3 000	Green (RoHS & no Sb/Br)	F6372
LTA6374XS14/R5	SOIC-14L	Tape and Reel, 2 500	Green (RoHS & no Sb/Br)	F6374
LTA6374XT14/R6	TSSOP-14L	Tape and Reel, 3 000	Green (RoHS & no Sb/Br)	F6374

(1) Please contact to your Linearin representative for the latest availability information and product content details.

(2) Eco Class - The planned eco-friendly classification: Pb-Free (RoHS) or Green (RoHS & Halogen Free).

(3) There may be multiple device markings, a varied marking character of "x", or additional marking, which relates to the logo, the lot trace code information, or the environmental category on the device.

## Limiting Value

In accordance with the Absolute Maximum Rating System (IEC60134).

Parameter	Absolute Maximum Rating
Supply Voltage, $V_{S+}$ to $V_{S-}$	36 V
Signal Input Terminals: Voltage	$V_{S-} - 0.5$ V to $V_{S+} + 0.5$ V
Signal Input Terminals: Current	$\pm 10$ mA
Output Short-Circuit	Continuous
Storage Temperature Range, $T_{stg}$	$-65$ °C to $+150$ °C
Junction Temperature, $T_j$	150 °C
Lead Temperature Range (Soldering 10 sec)	260 °C

## ESD Ratings

Parameter	Level	UNIT
Human body model (HBM), per ANSI/ESDA/JEDEC JS-001	$\pm 3000$	V
Charged device model (CDM), per ANSI/ESDA/JEDEC JS-002	$\pm 1500$	V

## Thermal Information

Thermal Metric	Package	Level	Unit
$\theta_{JA}$ Package Thermal Resistance	SOT23-5L	190	°C/W
	SOIC-8L	125	
	MSOP-8L	201	
	DFN3×3-8L	94	
	SOIC-14L	115	
	TSSOP-14L	112	

### Electrical Characteristics

$V_S = 36\text{ V}$ ,  $T_A = +25\text{ }^\circ\text{C}$ ,  $V_{CM} = V_S/2$ ,  $V_O = V_S/2$ , and  $R_L = 10\text{ k}\Omega$  connected to  $V_S/2$ , unless otherwise noted.

Parameter	Symbol	Conditions	Min.	Typ.	Max.	Unit
<b>POWER SUPPLY</b>						
Supply Voltage Range	$V_S$		4		36	V
Quiescent Current per Amplifier	$I_Q$	$V_S = 36\text{ V}$	0.75	1.20	1.75	mA
		$V_S = 5\text{ V}$	0.65	0.90	1.15	
Power supply rejection ratio	PSRR	$V_S = 4\text{ to }36\text{ V}$ , $T_A = 25^\circ\text{C}$	95	100		dB
		$V_S = 4\text{ to }36\text{ V}$ , $T_A = -40\sim 125^\circ\text{C}$	90	98		
<b>INPUT CHARACTERISTICS</b>						
Input Offset Voltage	$V_{OS}$	$T_A = 25^\circ\text{C}$	-4		4	mV
		$T_A = -40\sim 125^\circ\text{C}$		$\pm 1.5$	5	
Input Offset Voltage Drift	$dV_{OS}/dT$			5		$\mu\text{V}/^\circ\text{C}$
Input Bias Current	$I_B$	$T_A = 25^\circ\text{C}$		9		pA
		$T_A = 85^\circ\text{C}$		100		
		$T_A = 125^\circ\text{C}$		1400		
Input Offset Current	$I_{OS}$	$T_A = 25^\circ\text{C}$		9		pA
Input Capacitance	$C_{IN}$			3.5		pF
Open-loop Voltage Gain	$A_V$	$V_S = 36\text{ V}$ , $T_A = -40\sim 125^\circ\text{C}$	90	100		dB
Common-mode voltage range	$V_{CM}$		$V_S - 0.1$		$V_S - 1.5$	V
Common-mode rejection ratio	CMRR	$V_{cm} = 0\text{V}\sim 34\text{V}$ , $T_A = 25^\circ\text{C}$	90	105		dB
		$V_{cm} = 0\text{V}\sim 34\text{V}$ , $T_A = -40\sim 125^\circ\text{C}$	92	100		
		$V_{cm} = 0\text{V}\sim 30\text{V}$ , $T_A = 25^\circ\text{C}$	86	110		
		$V_{cm} = 0\text{V}\sim 30\text{V}$ , $T_A = -40\sim 125^\circ\text{C}$	100	105		
<b>OUTPUT CHARACTERISTICS</b>						
Output Swing from Positive Rail	$V_{OH}$	$R_L = 10\text{ k}\Omega$ to $V_S/2$		230	290	mV
		$R_L = 2\text{ k}\Omega$ to $V_S/2$		1000	1300	
Output Swing from Negative Rail	$V_{OL}$	$R_L = 10\text{ k}\Omega$ to $V_S/2$		130	150	mV
		$R_L = 2\text{ k}\Omega$ to $V_S/2$		600	900	
Output Short-Circuit Current	Source			28		mA
	Sink			35		
Capacitive Load Drive				200		pF
<b>AC SPECIFICATIONS</b>						
Gain-Bandwidth Product	GBW			6		MHz
Slew Rate	SR			10		V/ $\mu\text{s}$
Phase Margin	PM			68		deg

## Electrical Characteristics(Cont.)

$V_S = 36\text{ V}$ ,  $T_A = +25\text{ }^\circ\text{C}$ ,  $V_{CM} = V_S/2$ ,  $V_O = V_S/2$ , and  $R_L = 10\text{ k}\Omega$  connected to  $V_S/2$ , unless otherwise noted.

Parameter	Symbol	Conditions	Min.	Typ.	Max.	Unit
<b>NOISE PERFORMANCE</b>						
Input Voltage Noise	$E_N$	$f = 0.1\text{ Hz to }10\text{ Hz}$		30		$\mu\text{V}_{pp}$
Input Voltage Noise Density	$e_N$	$f = 1\text{ kHz}$		50		$\text{nV}/\sqrt{\text{Hz}}$
		$f = 10\text{ kHz}$		23		$\text{nV}/\sqrt{\text{Hz}}$
Total Harmonic Distortion and Noise	THD+N	$f = 1\text{ kHz}$ , $G=1$ , $R_L = 10\text{ k}\Omega$ , $V_{out}=3V_{RMS}$		0.0001		%

Typical Characteristics

At  $T_A = 25^\circ\text{C}$ ,  $V_S = 36\text{ V}$ ,  $V_{CM} = V_S / 2$  and  $R_L = 10\text{ k}\Omega$  connected to  $V_S / 2$ , unless otherwise noted.

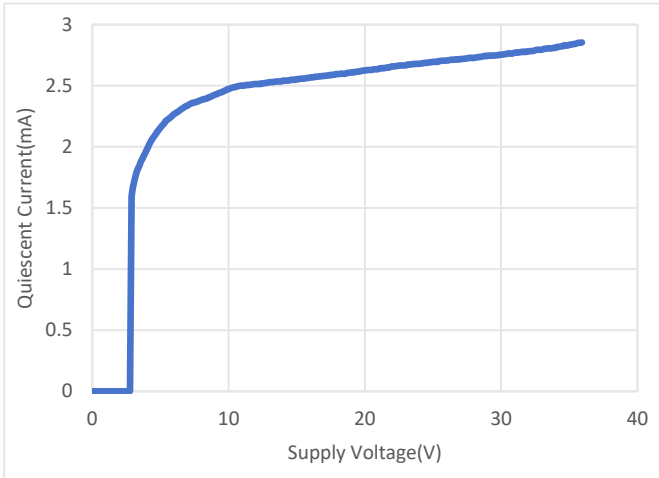

Figure 1. LTA6372 Quiescent Current vs Supply

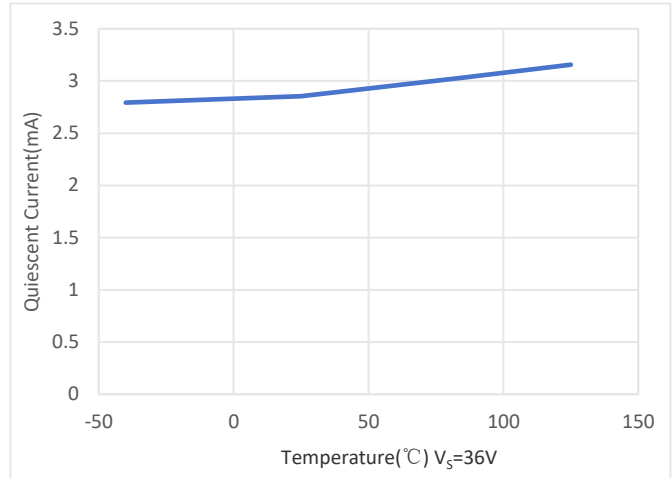

Figure 2. LTA6372 Quiescent Current vs Temperature

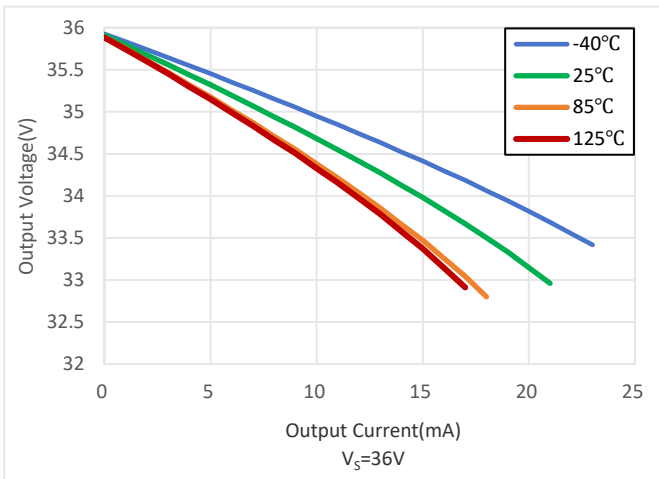

Figure 3. Output Voltage Swing as a function of Output Current (Sourcing,  $V_S = 36\text{ V}$ )

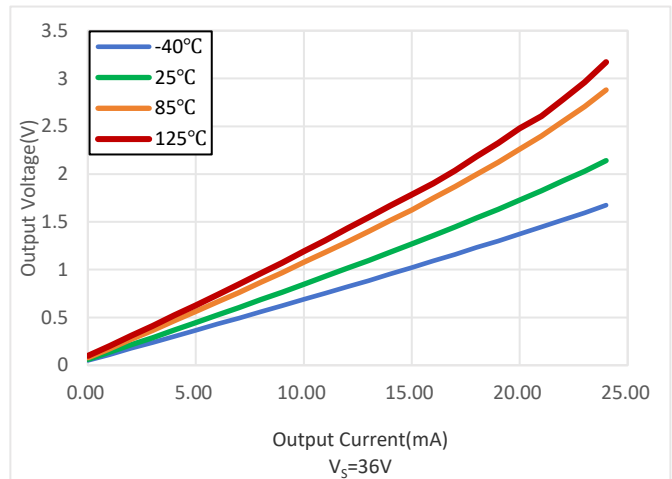

Figure 4. Output Voltage Swing as a function of Output Current (Sinking,  $V_S = 36\text{ V}$ )

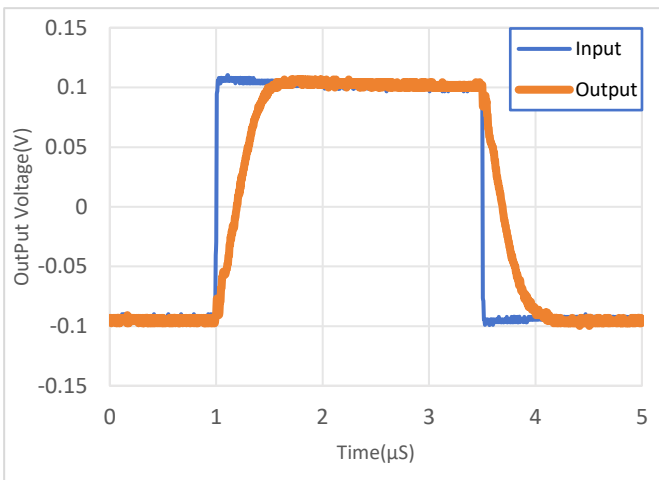

Figure 5. Small-Signal Step Response

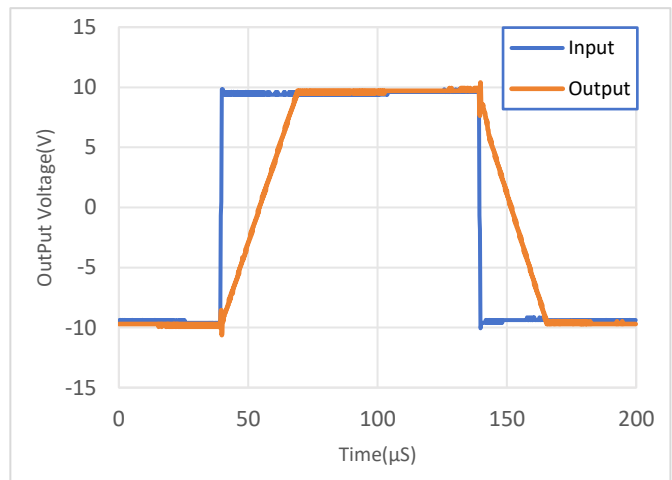

Figure 6. Large-Signal Step Response

Typical Characteristics(Cont.)

At  $T_A = 25^\circ\text{C}$ ,  $V_S = 36\text{ V}$ ,  $V_{CM} = V_S / 2$  and  $R_L = 10\text{ k}\Omega$  connected to  $V_S / 2$ , unless otherwise noted.

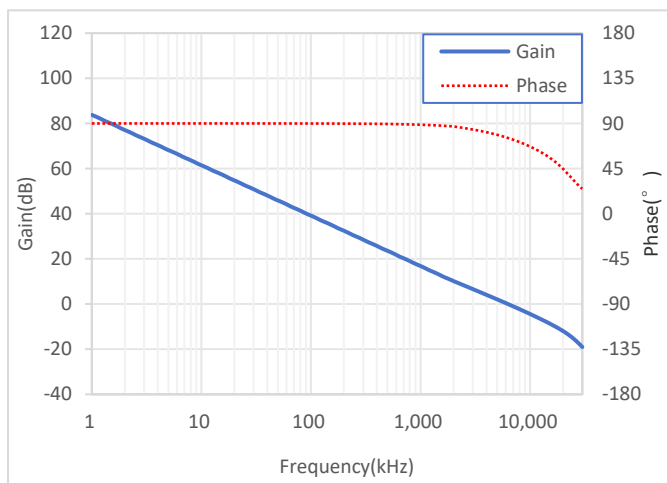

Figure 7. Open Loop Gain and Phase vs Frequency

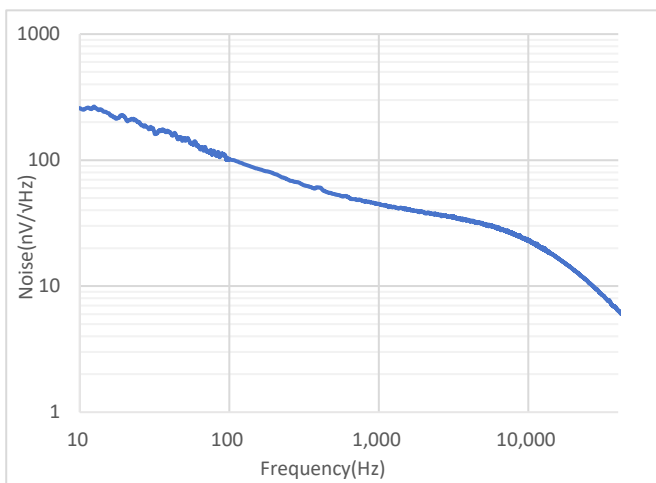
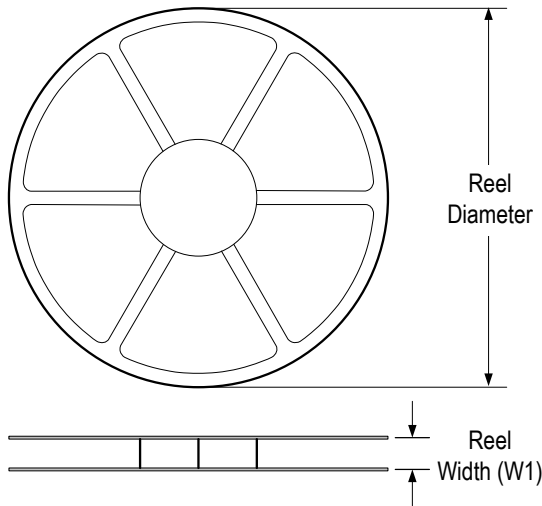

Figure 8. Voltage Noise Density vs. Frequency

Tape and Reel Information

REEL DIMENSIONS



TAPE DIMENSIONS

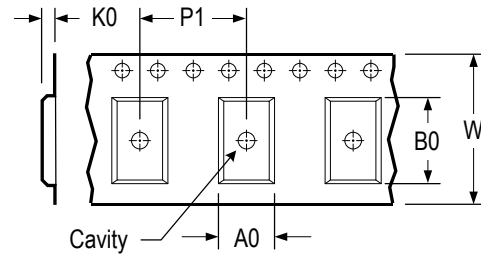

A0	Dimension designed to accommodate the component width
B0	Dimension designed to accommodate the component length
K0	Dimension designed to accommodate the component thickness
W	Overall width of the carrier tape
P1	Pitch between successive cavity centers

QUADRANT ASSIGNMENTS FOR PIN 1 ORIENTATION IN TAPE

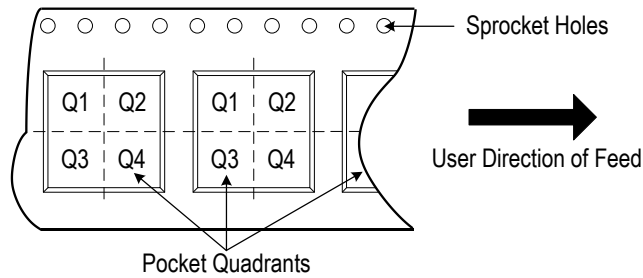

\* All dimensions are nominal

Device	Package Type	Pins	SPQ	Reel Diameter (mm)	Reel Width W1 (mm)	A0 (mm)	B0 (mm)	K0 (mm)	P1 (mm)	W (mm)	Pin 1 Quadrant
LTA6371XT5/R6	SOT23	5	3 000	178	9.0	3.3	3.2	1.5	4.0	8.0	Q3
LTA6371XS8/R8	SOIC	8	4 000	330	12.5	6.6	5.3	2.0	8.0	12.0	Q1
LTA6372XS8/R8	SOIC	8	4 000	330	12.5	6.6	5.3	2.0	8.0	12.0	Q1
LTA6372XV8/R6	MSOP	8	3 000	330	12.5	5.0	3.5	2.0	8.0	12.0	Q1
LTA6372XF8/R6	DFN3×3	8	3 000	330	12.5	3.3	3.3	1.1	8.0	12.0	Q1
LTA6374XS14/R5	SOIC	14	2 500	330	12.5	6.5	9.5	2.0	8.0	16.0	Q1
LTA6374XT14/R6	TSSOP	14	3 000	330	12.5	6.9	5.5	1.2	8.0	16.0	Q1

Package Outlines

DIMENSIONS, SOT23-5L

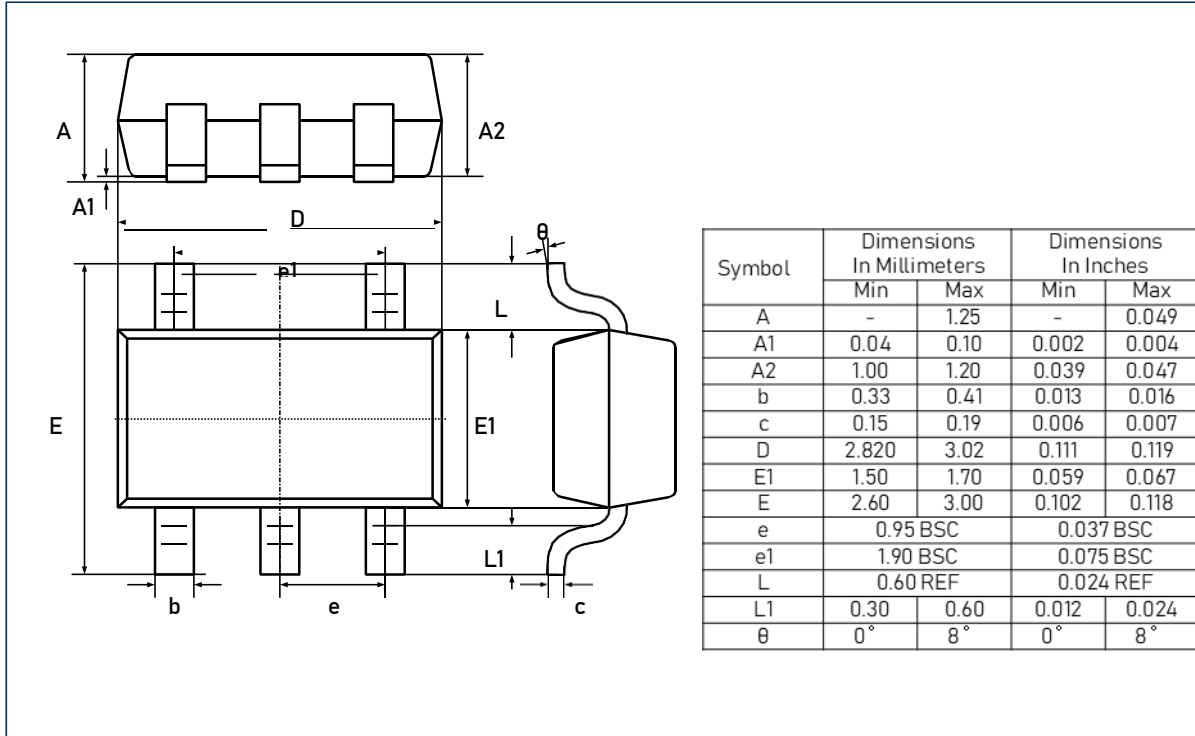

RECOMMENDED SOLDERING FOOTPRINT, SOT23-5L

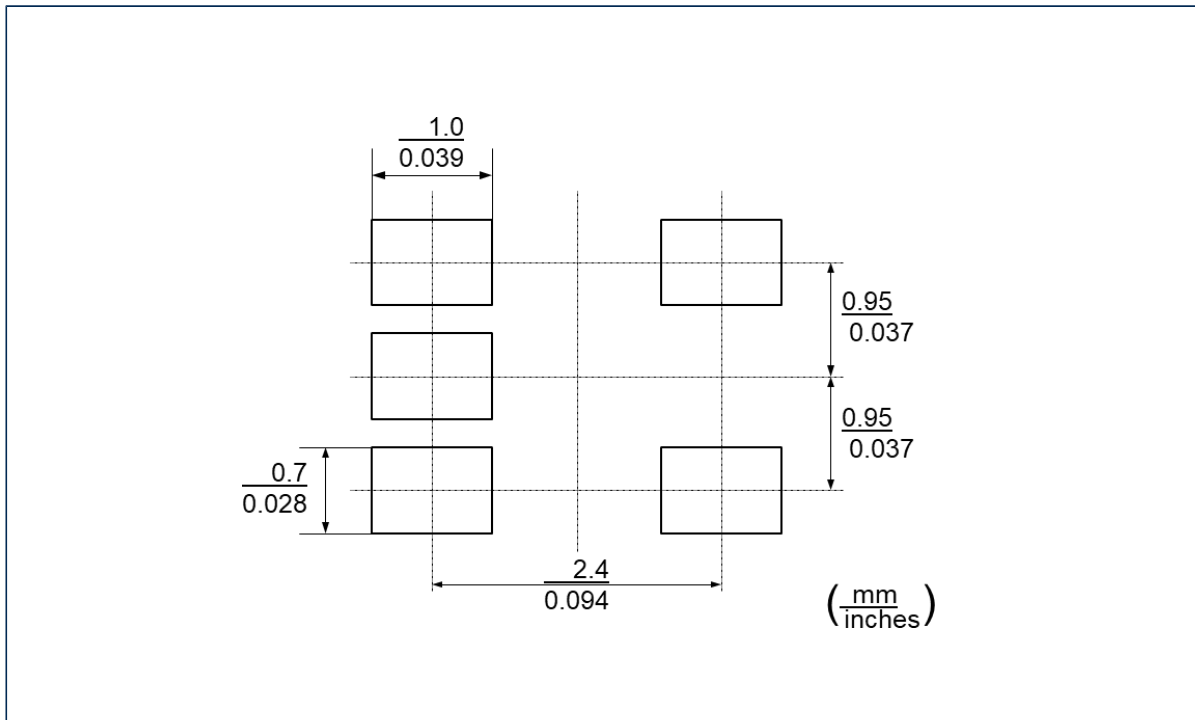

Package Outlines(Cont.)

DIMENSIONS, SOIC-8L

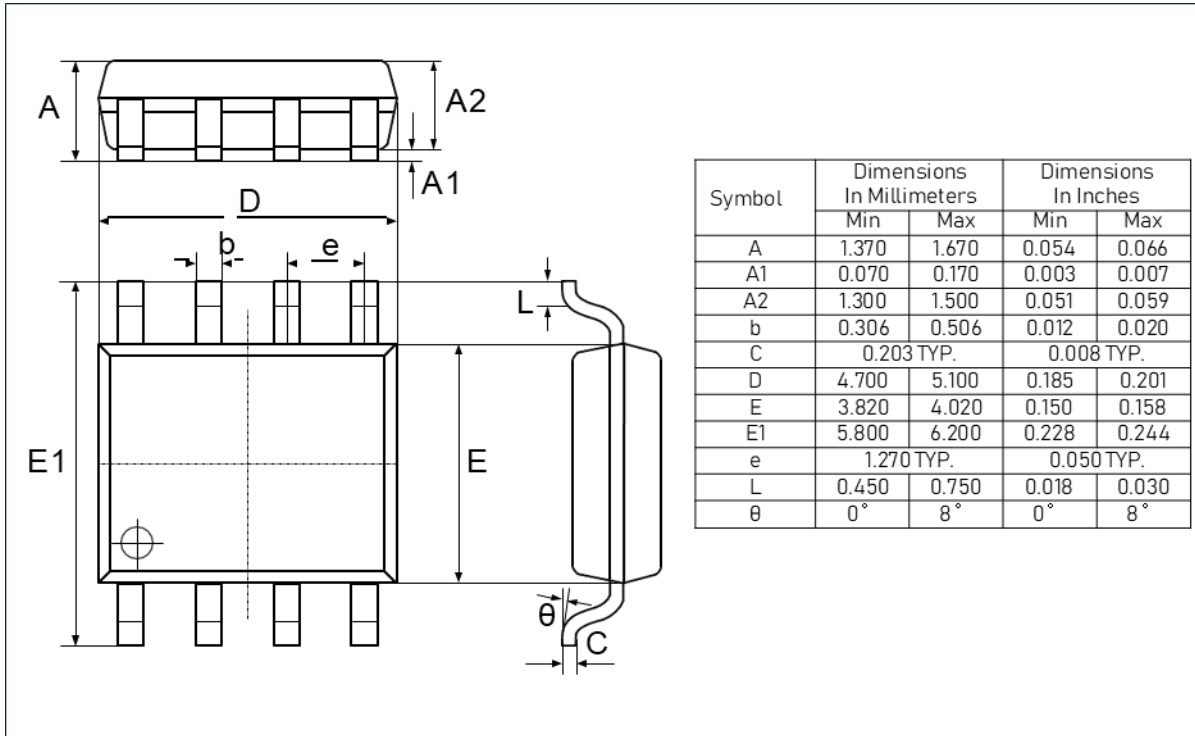

RECOMMENDED SOLDERING FOOTPRINT, SOIC-8L

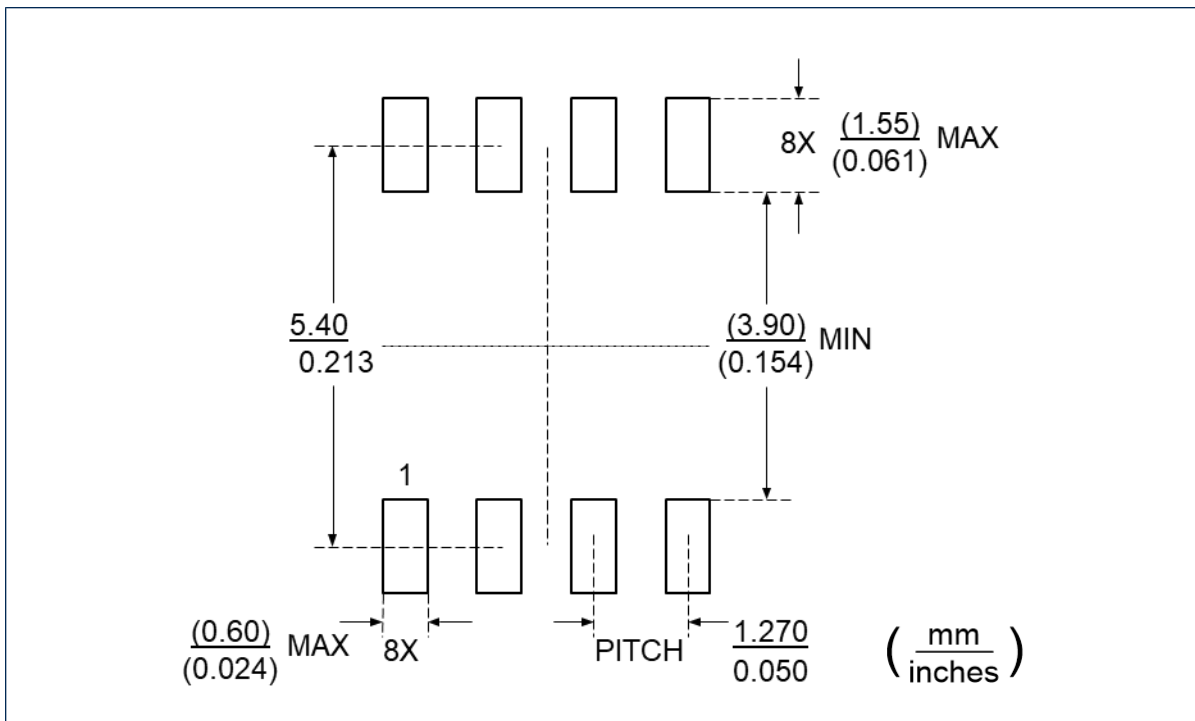

Package Outlines(Cont.)

DIMENSIONS, MSOP-8L

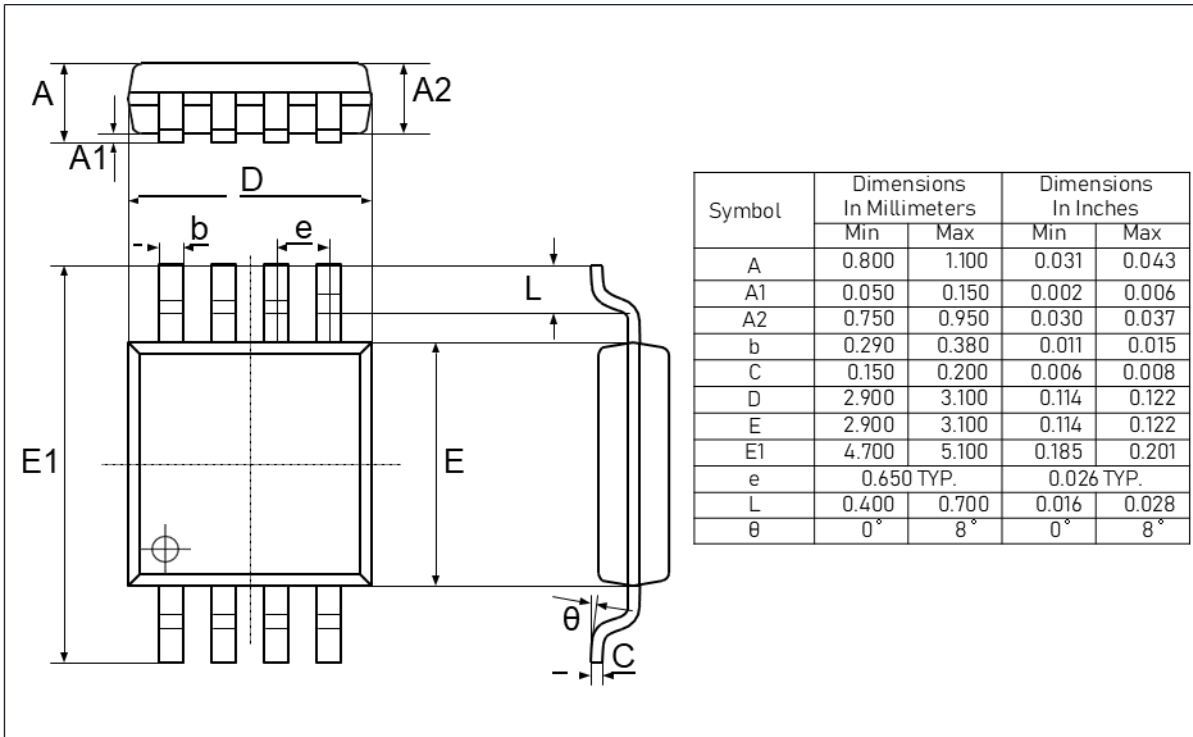

RECOMMENDED SOLDERING FOOTPRINT, MSOP-8L

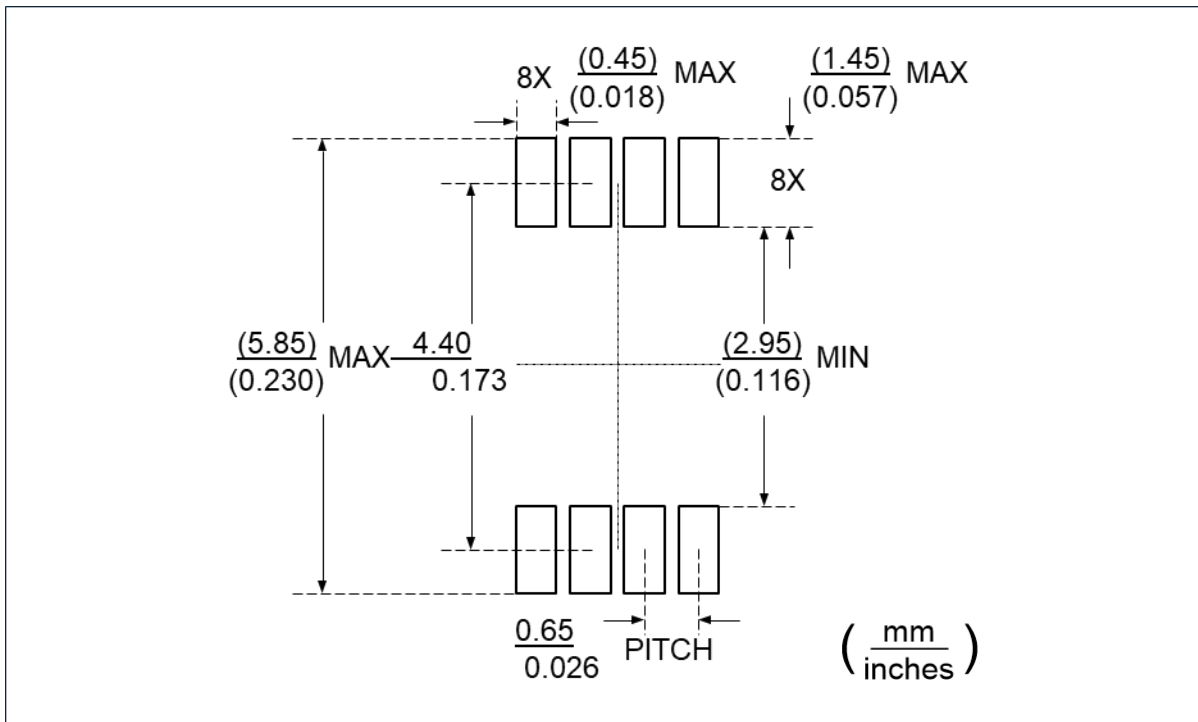

Package Outlines(Cont.)

DIMENSIONS, DFN3x3-8L

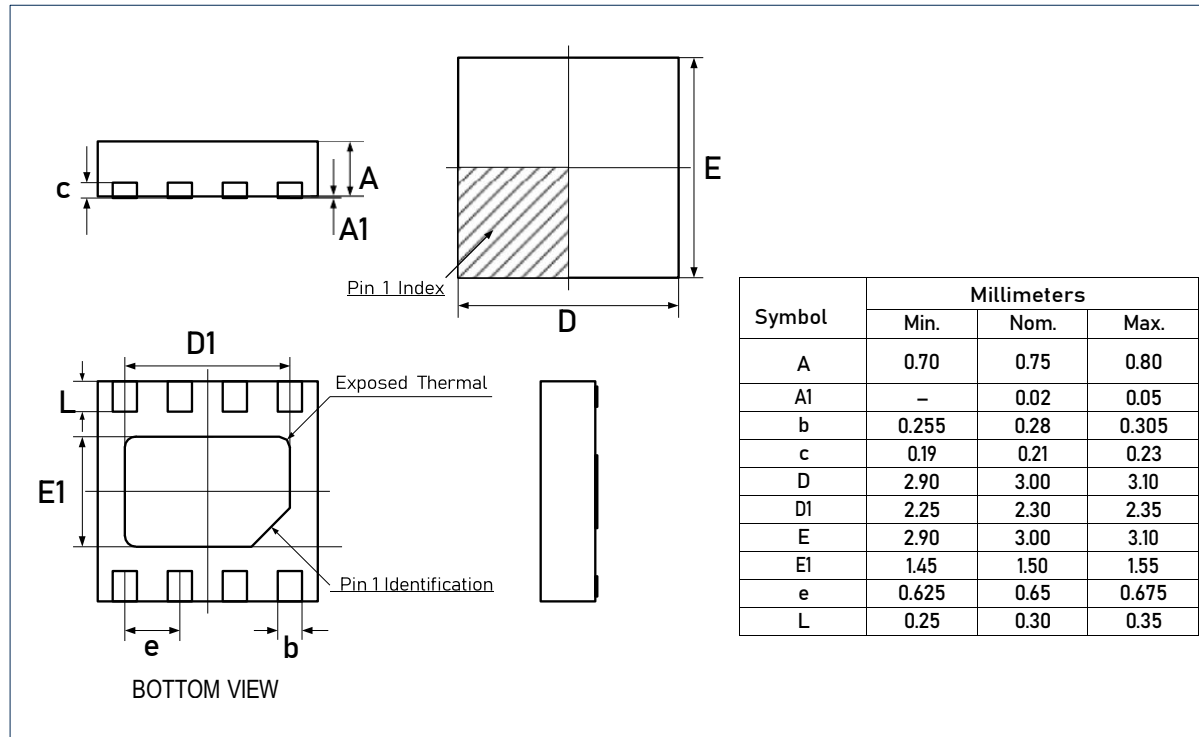

Package Outlines(Cont.)

DIMENSIONS, SOIC-14L

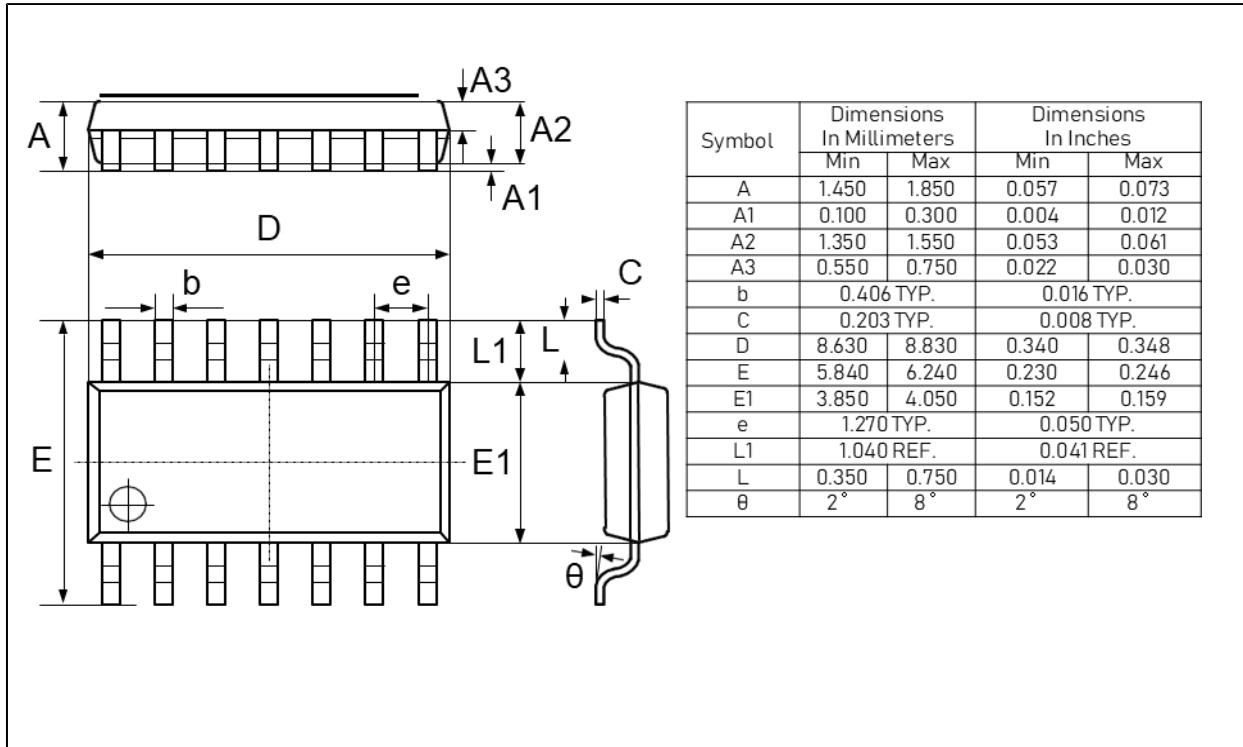

RECOMMENDED SOLDERING FOOTPRINT, SOIC-14L

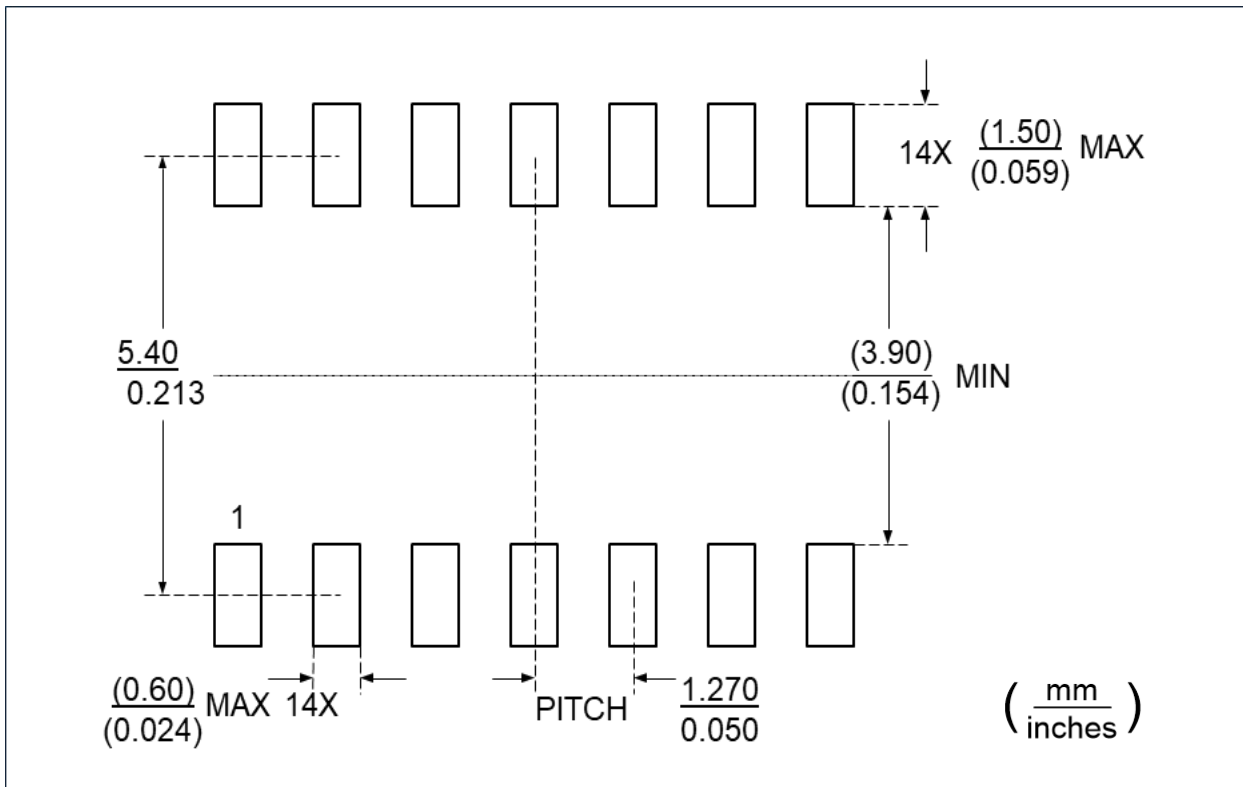

Package Outlines(Cont.)

DIMENSIONS, TSSOP-14L

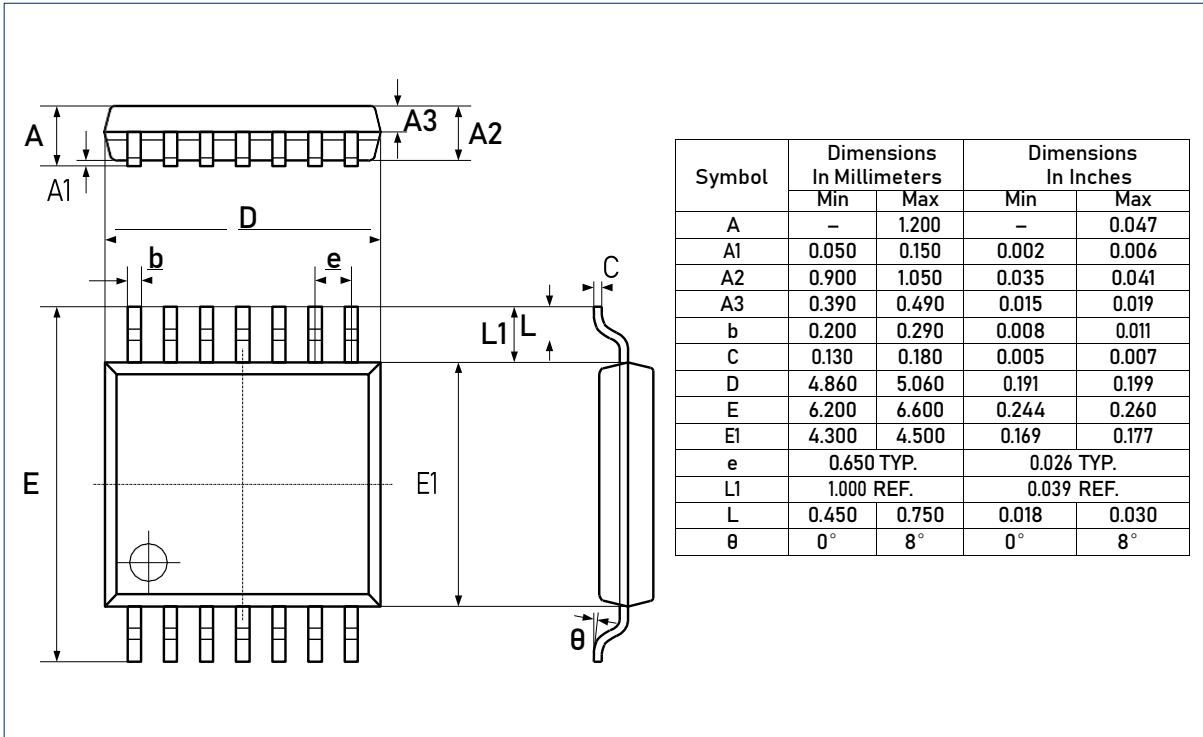

RECOMMENDED SOLDERING FOOTPRINT, TSSOP-14L

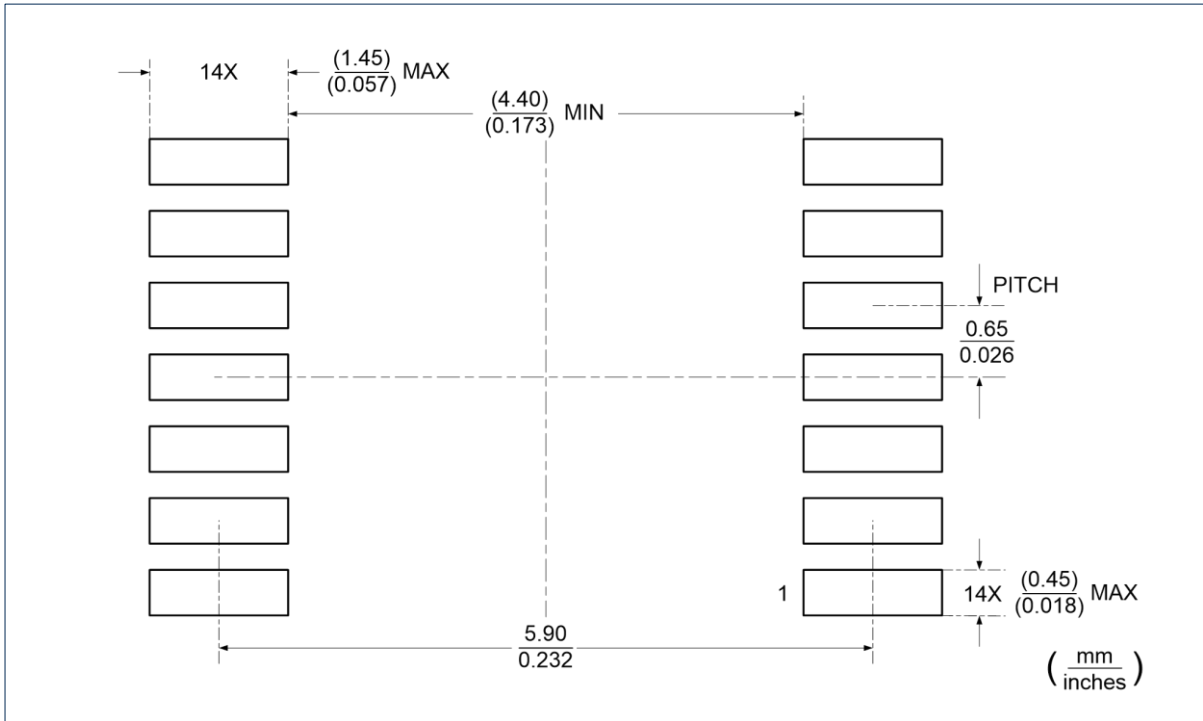

## Important Notice

---

Linearin is a global fabless semiconductor company specializing in advanced high-performance high-quality analog/mixed-signal IC products and sensor solutions. The company is devoted to the innovation of high performance, analog-intensive sensor front-end products and modular sensor solutions, applied in multi-market of medical & wearable devices, smart home, sensing of IoT, intelligent industrial & smart factory (industry 4.0), and automotives. Linearin's product families include widely-used standard catalog products, solution-based application specific standard products (ASSPs) and sensor modules that help customers achieve faster time-to-market products. Go to <http://www.linearin.com> for a complete list of Linearin product families.

For additional product information, or full datasheet, please contact with the Linearin's Sales Department or Representatives.