

General Description

The LTC8635Q is a single channel operational amplifier, representing a new generation of general-purpose, low-power operational amplifiers. Featuring rail-to-rail input and output (RRIO) swings, low quiescent current (typical 750 μ A) combined with a wide bandwidth (11 MHz) makes this family very attractive for a variety of battery-powered applications that require a good balance between cost and performance, such as audio outputs, motor phase current sensing, photodiode amplification, barcode scanners and white goods. The low input bias current supports these amplifiers to be used in applications with mega-ohm source impedances.

The robust design of the LTC8635Q amplifiers provides ease-of-use to the circuit designer: unity-gain stability with capacitive loads of up to 300 pF, integrated RF/EMI rejection filter, no phase reversal in overdrive conditions, and high electro-static discharge (ESD) protection. The LTC8635Q amplifiers are optimized for operation at voltages as low as +2.0 V (\pm 1.0 V) to +5.5 V (\pm 2.75 V) over the extended temperature range of -40°C to $+125^{\circ}\text{C}$.

The LTC8635Q is available in SOT23-5L.

Features and Benefits

- Low Input Offset Voltage: \pm 0.35 mV Maximum
- Wide Unity-Gain Bandwidth: 11 MHz
- High Slew Rate: 11 V/ μ s
- Fast Settling: 0.26 μ s to 0.1%
- Rail-to-Rail Input and Output
- Internal RF/EMI Filter
- Single 2 V to 5.5 V Supply Voltage Range
- Low Supply Current: 750 μ A at 5V Supply Per Amplifier
- Extended Temperature Range: -40°C to $+125^{\circ}\text{C}$
- Optimized for AEC-Q100 grade 1 applications

Applications

- Automotive headlighting
- On-Board Charger (OBC)
- Body Electronics
- Inverter and motor control
- Battery management system (BMS)

Pin Configurations (Top View)

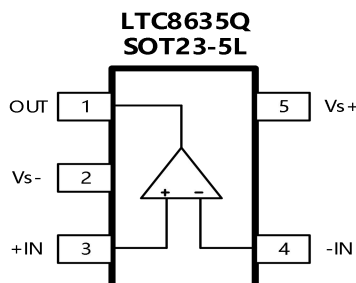

Table of Content

General Description	1
Features and Benefits	1
Applications	1
Pin Configuration (Top View).....	1
Table of Content	2
Pin Description	3
Ordering Information	3
Limiting Value.....	3
ESD Ratings	3
Electrical Characteristics	4
Typical Performance Characteristics.....	6
Tape and Reel Information	7
Package Outlines	8
Important Notice	9

Pin Description

Symbol	Description
-IN	Inverting input of the amplifier. The voltage range is from ($V_{S-} - 0.1V$) to ($V_{S+} + 0.1V$).
+IN	Non-inverting input of the amplifier. This pin has the same voltage range as -IN.
V_{S+}	Positive power supply.
V_{S-}	Negative power supply.
OUT	Amplifier output.

Ordering Information

Type Number	Package Name	Package Quantity	Marking Code ⁽¹⁾
LTC8635QT5/R6	SOT23-5L	Tape and Reel, 3 000	QH8YW

(1) There may be multiple device markings, a varied marking character of "x", or additional marking, which relates to the logo, the lot trace code information, or the environmental category on the device.

Limiting Value

Parameter	Absolute Maximum Rating
Supply Voltage, V_{S+} to V_{S-}	10.0 V
Signal Input Terminals: Voltage, Current	$V_{S-} - 0.5 V$ to $V_{S+} + 0.5 V$, ± 10 mA
Output Short-Circuit	Continuous
Storage Temperature Range, T_{stg}	-65 °C to $+150$ °C
Junction Temperature, T_j	150 °C
Lead Temperature Range (Soldering 10 sec)	260 °C

ESD Rating

Parameter	Item	Value	Unit
Electrostatic Discharge Voltage	Human body model (HBM), per AEC-Q100-002	$\pm 2\ 000$	V
	Charged device model (CDM), per AEC-Q100-011	$\pm 2\ 000$	

Electrical Characteristics

$V_S = 5.0V$, $T_A = +25^\circ C$, $V_{CM} = V_S/2$, $V_O = V_S/2$, and $R_L = 10k\Omega$ connected to $V_S/2$, unless otherwise noted.

Symbol	Parameter	Conditions	Min.	Typ.	Max.	Unit
OFFSET VOLTAGE						
V_{OS}	Input offset voltage			± 0.10	± 0.35	mV
$V_{OS\ TC}$	Offset voltage drift	$T_A = -40$ to $+125^\circ C$		± 1	2.3	$\mu V/^\circ C$
PSRR	Power supply rejection ratio	$V_S = 2.0$ to $5.5V$, $V_{CM} < V_{S+} - 2V$	95	110		dB
		$T_A = -40$ to $+125^\circ C$	82			
INPUT BIAS CURRENT						
I_B	Input bias current			1		pA
		$T_A = +85^\circ C$		150		
		$T_A = +125^\circ C$		500		
I_{OS}	Input offset current			1		pA
NOISE						
V_n	Input voltage noise	$f = 0.1$ to $10\ Hz$		10		μV_{P-P}
e_n	Input voltage noise density	$f = 10\ kHz$		20		nV/\sqrt{Hz}
I_n	Input current noise density	$f = 1\ kHz$		3		fA/\sqrt{Hz}
INPUT VOLTAGE						
V_{CM}	Common-mode voltage range		$V_{S-} - 0.1$		$V_{S+} + 0.1$	V
CMRR	Common-mode rejection ratio	$V_S = 5.5V$, $V_{CM} = -0.1$ to $5.6V$	80	96		dB
		$V_{CM} = 0$ to $5.3V$, $T_A = -40$ to $+125^\circ C$	75			
		$V_S = 2.0V$, $V_{CM} = -0.1$ to $2.1V$	76	90		
		$V_{CM} = 0$ to $1.8V$, $T_A = -40$ to $+125^\circ C$	70			
INPUT IMPEDANCE						
C_{IN}	Input capacitance	Differential		2.0		pF
		Common mode		3.5		
OPEN-LOOP GAIN						
A_{VOL}	Open-loop voltage gain	$R_L = 10\ k\Omega$, $V_O = 0.05$ to $3.5V$	97	105		dB
		$T_A = -40$ to $+125^\circ C$	87			
		$R_L = 600\ \Omega$, $V_O = 0.15$ to $3.5V$	85	90		
		$T_A = -40$ to $+125^\circ C$	75			
FREQUENCY RESPONSE						
GBW	Gain bandwidth product			11		MHz
SR	Slew rate	$G = +1$, $C_L = 100\ pF$, $V_O = 1.5$ to $3.5V$		11		$V/\mu s$
THD+N	Total harmonic distortion + noise	$G = +1$, $f = 1\ kHz$, $V_O = 0.5\ V_{RMS}$		0.0005		%
t_S	Settling time	To 0.1%, $G = +1$, 1V step		0.26		μs
		To 0.01%, $G = +1$, 1V step		0.34		
t_{OR}	Overload recovery time	$V_{IN} * Gain > V_S$		0.3		μs

CAUTION: These devices are sensitive to electrostatic discharge; follow proper IC Handling Procedures.

Linearin and designs are registered trademarks of Linearin Technology Corporation.

© Copyright Linearin Technology Corporation. All Rights Reserved.

All other trademarks mentioned are the property of their respective owners.

Electrical Characteristics (continued)

$V_S = 5.0V$, $T_A = +25^\circ C$, $V_{CM} = V_S/2$, $V_O = V_S/2$, and $R_L = 10k\Omega$ connected to $V_S/2$, unless otherwise noted.

Symbol	Parameter	Conditions	Min.	Typ.	Max.	Unit
OUTPUT						
V_{OH}	High output voltage swing	$R_L = 10\text{ k}\Omega$	$V_{S+}-12$	$V_{S+}-8$		mV
		$R_L = 600\ \Omega$	$V_{S+}-180$	$V_{S+}-125$		
V_{OL}	Low output voltage swing	$R_L = 10\text{ k}\Omega$		$V_{S-}+6$	$V_{S-}+9$	mV
		$R_L = 600\ \Omega$		$V_{S-}+90$	$V_{S-}+130$	
I_{SC}	Short-circuit current			± 75		mA
POWER SUPPLY						
V_S	Operating supply voltage	$T_A = -40\text{ to }+125\ ^\circ C$	2.0		5.5	V
I_q	Quiescent current (per amplifier)	$V_S = 2.0\text{ V}$		625	760	μA
		$V_S = 5.0\text{ V}$		750	930	
THERMAL CHARACTERISTICS						
T_A	Operating temperature range		-40		+125	$^\circ C$
θ_{JA}	Package Thermal Resistance	SOT23-5L		190		$^\circ C/W$

Typical Characteristics

$V_S = 5.0V$, $T_A = +25^\circ C$, $V_{CM} = V_S/2$, $V_O = V_S/2$, and $R_L = 10k\Omega$ connected to $V_S/2$, unless otherwise noted.

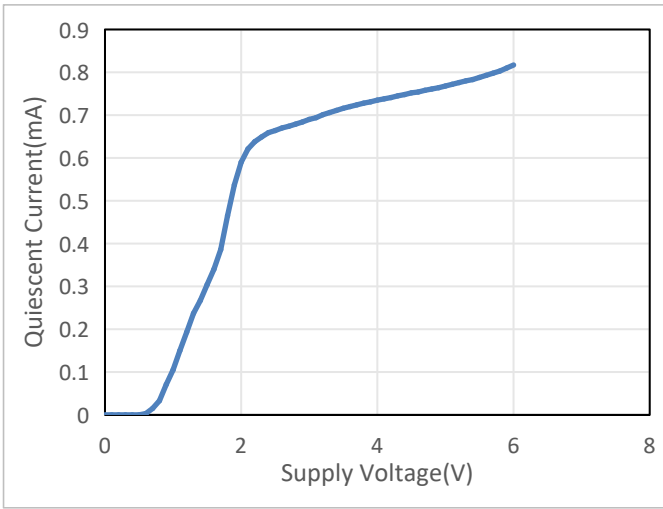

Quiescent Current as a function of Supply Voltage

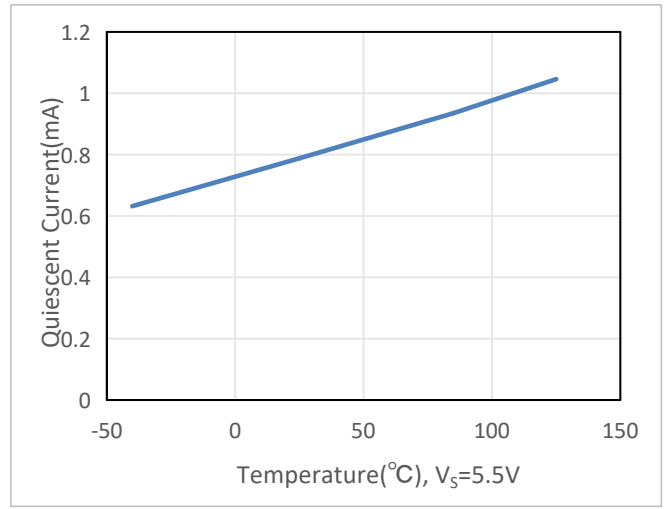

Quiescent Current as a function of Temperature

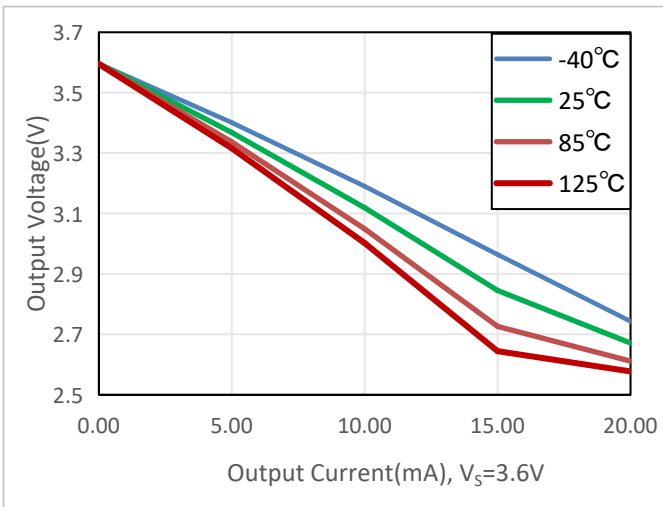

Output Voltage Swing as a function of Output Current (Sourcing, $V_S = 3.6V$)

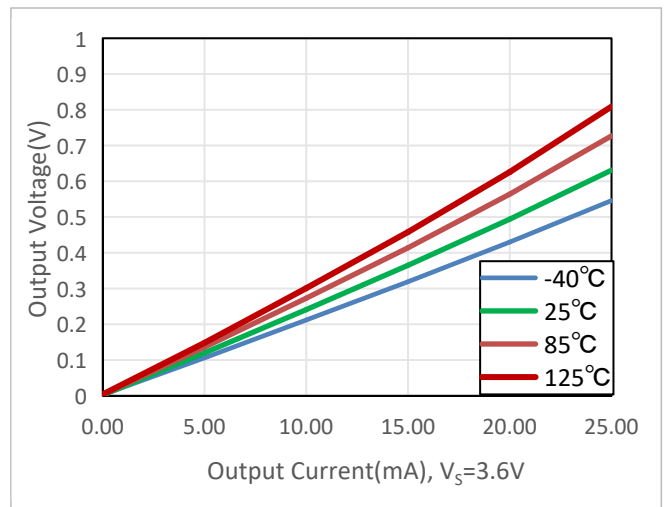

Output Voltage Swing as a function of Output Current (Sinking, $V_S = 3.6V$)

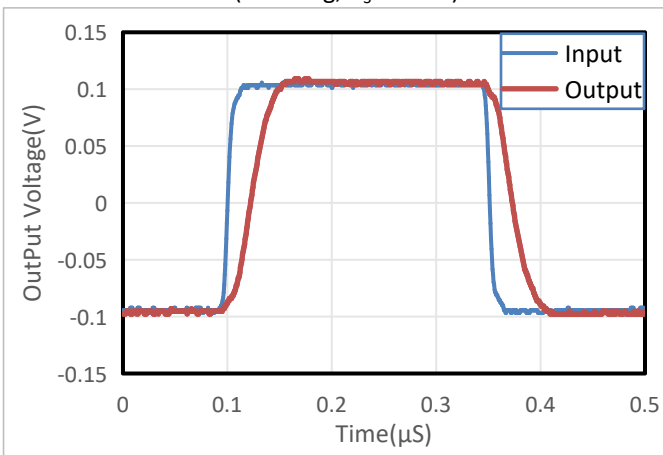

Small-Signal Step Response

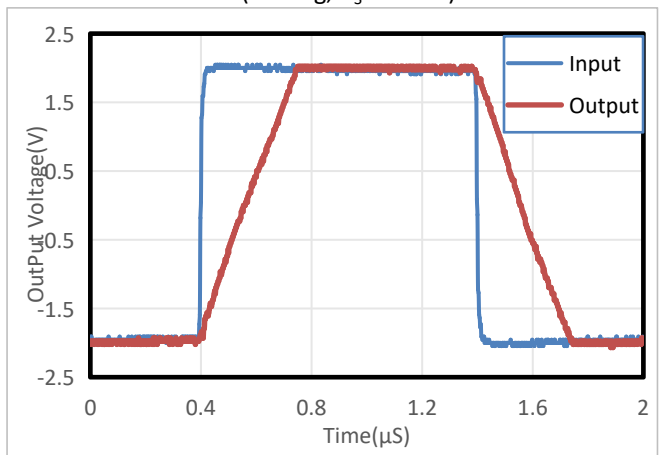

Large-Signal Step Response

CAUTION: These devices are sensitive to electrostatic discharge; follow proper IC Handling Procedures. Linearin and designs are registered trademarks of Linearin Technology Corporation. © Copyright Linearin Technology Corporation. All Rights Reserved. All other trademarks mentioned are the property of their respective owners.

Tape and Reel Information

REEL DIMENSIONS

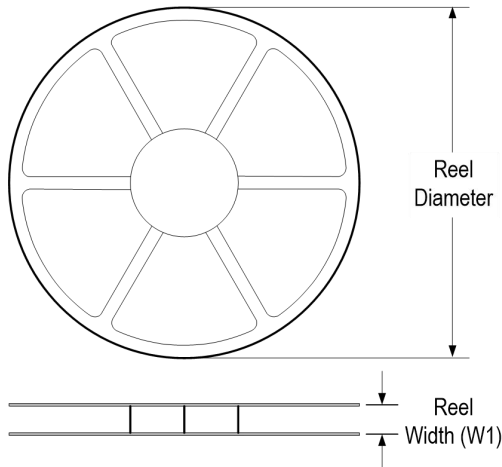

TAPE DIMENSIONS

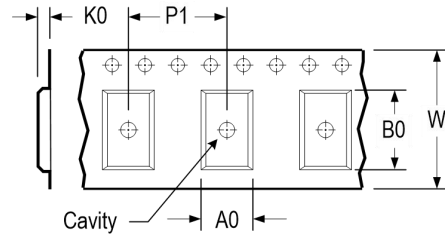

A0	Dimension designed to accommodate the component width
B0	Dimension designed to accommodate the component length
K0	Dimension designed to accommodate the component thickness
W	Overall width of the carrier tape
P1	Pitch between successive cavity centers

QUADRANT ASSIGNMENTS FOR PIN 1 ORIENTATION IN TAPE

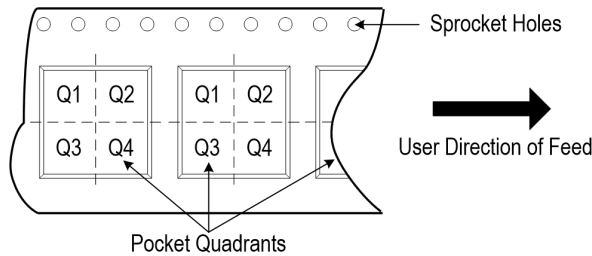

* All dimensions are nominal

Device	Package Type	Pins	SPQ	Reel Diameter (mm)	Reel Width W1 (mm)	A0 (mm)	B0 (mm)	K0 (mm)	P1 (mm)	W (mm)	Pin 1 Quadrant
LTC8635QT5/R6	SOT23	5	3 000	178	9.5	3.3	3.2	1.5	4.0	8.0	Q3

Package Outlines

DIMENSIONS, SOT23-5L

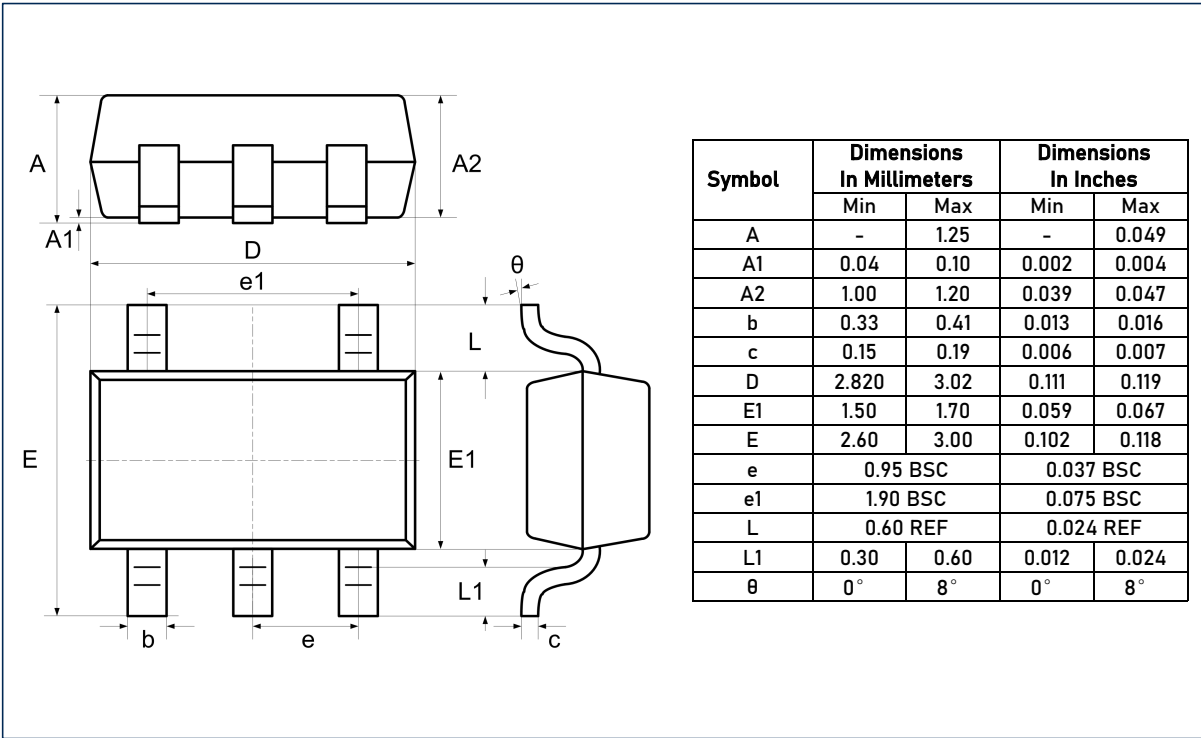

RECOMMENDED SOLDERING FOOTPRINT, SOT23-5L

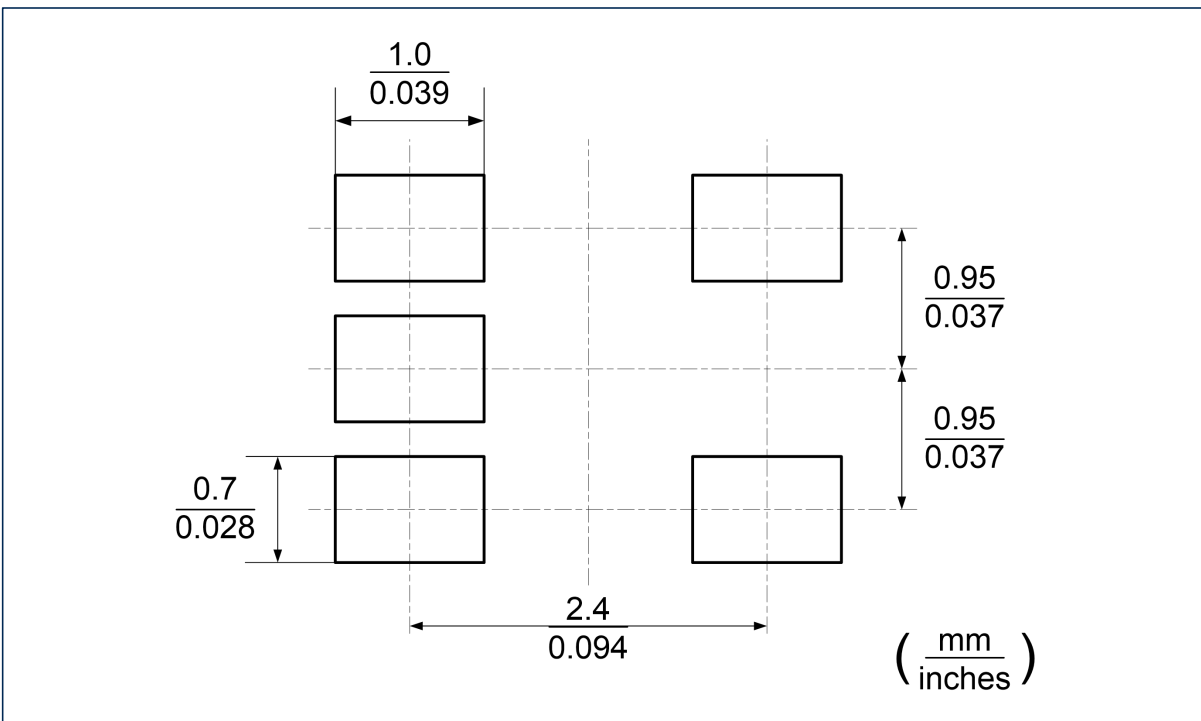

CAUTION: These devices are sensitive to electrostatic discharge; follow proper IC Handling Procedures.
 Linearin and designs are registered trademarks of Linearin Technology Corporation.
 © Copyright Linearin Technology Corporation. All Rights Reserved.
 All other trademarks mentioned are the property of their respective owners.

IMPORTANT NOTICE

Linearin is a global fabless semiconductor company specializing in advanced high-performance high-quality analog/mixed-signal IC products and sensor solutions. The company is devoted to the innovation of high performance, analog-intensive sensor front-end products and modular sensor solutions, applied in multi-market of medical & wearable devices, smart home, sensing of IoT, and intelligent industrial & smart factory (industry 4.0). Linearin's product families include widely-used standard catalog products, solution-based application specific standard products (ASSPs) and sensor modules that help customers achieve faster time-to-market products. Go to <http://www.linearin.com> for a complete list of Linearin product families.

For additional product information, or full datasheet, please contact with the Linearin's Sales Department or Representatives.