

General Description

The LTA809xE family (LTA8091E, LTA8092E and LTA8094E) is a new generation of high voltage (48 V), low noise, precision operational amplifiers. These devices offer outstanding dc precision and ac performance, including low offset, low offset drift, 22-MHz bandwidth, and 4 nV/√Hz input voltage noise density at 10 kHz. Unique features such as differential input-voltage range to the negative supply rail, high output current (± 45 mA), high capacitive load drive of up to 1 nF, and high slew rate (17 V/μs) make the LTA809xE high-performance operational amplifiers for high-voltage industrial and medical applications.

The robust design of the LTA809xE family provides ease-of-use to the circuit designer: integrated RF/EMI rejection filter, no phase reversal in overdrive conditions, and high electro-static discharge (ESD) protection. The LTA809xE are optimized for operation at voltages from +4.5 V (± 2.25 V) to +48V (± 24 V) over the extended temperature range of -40 °C to +125 °C.

The LTA8091E (single) is available in both SOT23-5L and ESOP-8L packages. The LTA8092E (dual) is offered in ESOP-8L and EMSOP-8L packages. The quad-channel LTA8094E is offered in both SOIC-14L and ETSSOP-14L packages.

Features and Benefits

- Wide Supply: ± 2.25 V to ± 24 V, 4.5 V to 48 V
- Wide Bandwidth: 22 MHz GBW
- High Slew Rate: 17 V/μs
- Low Noise: 4 nV/√Hz at 10 kHz
- Low Offset Voltage: ± 350 μV Maximum
- Low Offset Voltage Drift: ± 1.5 μV/°C
- High Common-Mode Rejection: 110 dB
- Low Bias Current: 10 pA
- EMI/RFI Filtered Inputs

Applications

- High-Side and Low-Side Current Sensing
- Audio Preamplifier
- High Precision Comparator
- Multiplexed Data-Acquisition Systems
- High-Resolution ADC Driver Amplifiers
- SAR ADC Reference Buffers
- Test and Measurement Equipment
- Programmable Logic Controllers

Table of Content

General Description..... 1

Features and Benefits..... 1

Applications..... 1

Table of Content 2

Pin Configuration (Top View) 3

Pin Description..... 3

Ordering Information..... 3

Limiting Value-In accordance with the Absolute Maximum Rating System (IEC 60134) 4

ESD Rating 4

Electrical Characteristics 5

Typical Performance Characteristics..... 7

Tape and Reel Information.....10

Package Outlines11

Important Notice.....17

Pin Configuration (Top View)

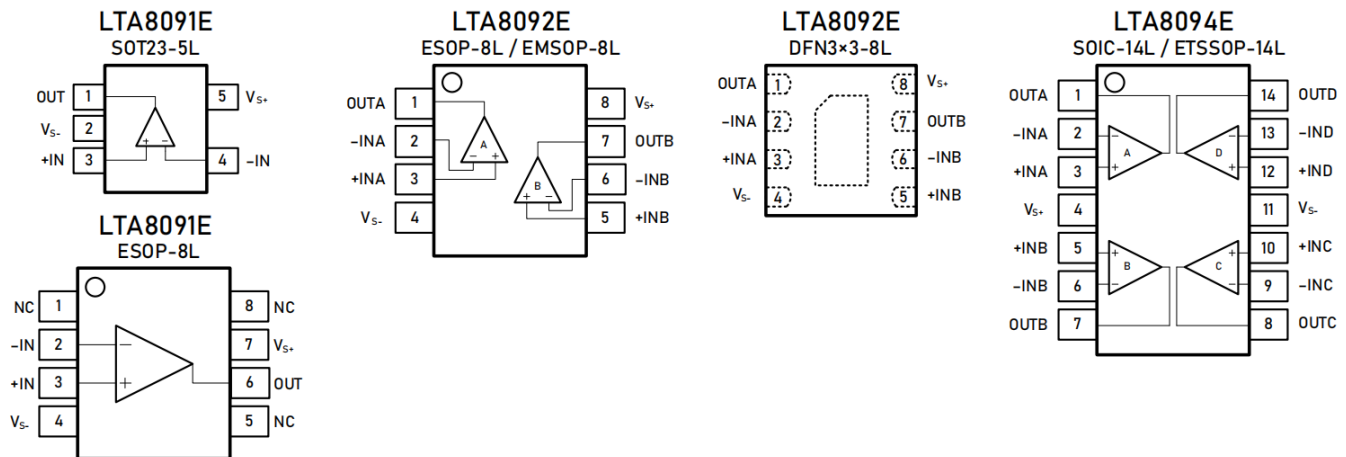

Pin Description

Symbol	Description
-IN	Inverting input of the amplifier. The voltage range is from V_{S-} to $V_{S+} - 1.5$ V.
+IN	Non-inverting input of the amplifier. This pin has the same voltage range as -IN.
V_{S+}	Positive power supply. The voltage is from 4.5 V to 48 V. Split supplies are possible as long as the voltage between V_{S+} and V_{S-} is from 4.5 V to 48 V.
V_{S-}	Negative power supply. It is normally tied to ground. It can also be tied to a voltage other than ground as long as the voltage between V_{S+} and V_{S-} is from 4.5 V to 48 V.
OUT	Amplifier output.
NC	No connection

Ordering Information

Type Number	Package Name	Package Quantity	Eco Class	Marking Code
LTA8091EXT5/R6	SOT23-5L	Tape and Reel, 3 000	Green (RoHS & no Sb/Br)	H91
LTA8091EXS8/R8	ESOP-8L	Tape and Reel, 4 000	Green (RoHS & no Sb/Br)	HV91E
LTA8092EXS8/R8	ESOP-8L	Tape and Reel, 4 000	Green (RoHS & no Sb/Br)	HV92E
LTA8092EXV8/R6	EMSOP-8L	Tape and Reel, 3 000	Green (RoHS & no Sb/Br)	HV92E
LTA8092EXF8/R10	DFN3x3-8L	Tape and Reel, 5 000	Green (RoHS & no Sb/Br)	HV92E
LTA8094EXS14/R5	SOIC-14L	Tape and Reel, 2 500	Green (RoHS & no Sb/Br)	HV94E
LTA8094EXT14/R6	ETSSOP-14L	Tape and Reel, 3 000	Green (RoHS & no Sb/Br)	HV94E

Limiting Value-In accordance with the Absolute Maximum Rating System (IEC 60134).

Parameter	Absolute Maximum Rating
Supply Voltage, V_{S+} to V_{S-}	60 V
Signal Input Terminals: Voltage, Current	$-V_S - 0.3$ V to $+V_S + 0.3$ V, ± 10 mA
Output Short-Circuit	Continuous
Storage Temperature Range, T_{stg}	-65 °C to $+150$ °C
Junction Temperature, T_J	150 °C
Lead Temperature Range (Soldering 10 sec)	260 °C

ESD Rating

Parameter	Item	Value	Unit
Electrostatic Discharge Voltage	Human body model (HBM), per ANSI/ESDA/JEDEC JS-001	2 000	V
	Charged device model (CDM), per ANSI/ESDA/JEDEC JS-002	2 000	

48V, 22MHz, Low Noise, Precision Operational Amplifiers

Electrical Characteristics

$V_S = 4.5\text{ V to }48\text{ V}$, $T_A = +25\text{ }^\circ\text{C}$, $V_{CM} = V_{OUT} = V_S/2$, and $R_L = 10\text{ k}\Omega$ connected to $V_S/2$, unless otherwise noted. Boldface limits apply over the specified temperature range, $T_A = -40\text{ }^\circ\text{C to }+125\text{ }^\circ\text{C}$.

Parameter	Symbol	Conditions	Min.	Typ.	Max.	Unit
OFFSET VOLTAGE						
Input offset voltage	V_{OS}	$V_S = 48\text{ V}$		± 75	± 350	μV
		$T_A = -40\text{ to }+125\text{ }^\circ\text{C}$			± 400	
Offset voltage drift	$V_{OS\text{ TC}}$	$T_A = -40\text{ to }+125\text{ }^\circ\text{C}$		± 1.5		$\mu\text{V}/^\circ\text{C}$
Power supply rejection ratio	PSRR	$V_S = 4.5\text{ to }48\text{ V}$, $V_{CM} = 0.1\text{ V}$	90	115		dB
		$T_A = -40\text{ to }+125\text{ }^\circ\text{C}$		95		
INPUT BIAS CURRENT						
Input bias current	I_B			10		pA
		$T_A = -40\text{ to }+85\text{ }^\circ\text{C}$		150		
		$T_A = -40\text{ to }+125\text{ }^\circ\text{C}$		600		
Input offset current	I_{OS}			5		pA
NOISE						
Input voltage noise	V_n	$f = 0.1\text{ to }10\text{ Hz}$		3.6		μV_{P-P}
Input voltage noise density	e_n	$f = 1\text{ kHz}$		8		$\text{nV}/\sqrt{\text{Hz}}$
		$f = 10\text{ kHz}$		4		
Input current noise density	I_n	$f = 1\text{ kHz}$		5		$\text{fA}/\sqrt{\text{Hz}}$
INPUT VOLTAGE						
Common-mode voltage range	V_{CM}		V_{S-}		$V_{S+}-1.5$	V
Common-mode rejection ratio	CMRR	$V_S = 48\text{ V}$, $V_{CM} = 0\text{ to }46\text{ V}$	86	110		dB
		$V_{CM} = 0.1\text{ to }38\text{ V}$, $T_A = -40\text{ to }+125\text{ }^\circ\text{C}$		103		
		$V_S = 4.5\text{ V}$, $V_{CM} = 0\text{ to }2.5\text{ V}$	67	94		
		$V_{CM} = 0.1\text{ to }2.2\text{ V}$, $T_A = -40\text{ to }+125\text{ }^\circ\text{C}$		84		
INPUT IMPEDANCE						
Input capacitance	C_{IN}	Differential		2		pF
		Common mode		3.5		
OPEN-LOOP GAIN						
Open-loop voltage gain	A_{VOL}	$V_S = 48\text{ V}$, $V_O = 0.1\text{ to }39.9\text{ V}$	114	120		dB
		$T_A = -40\text{ to }+125\text{ }^\circ\text{C}$		105		
		$V_S = 4.5\text{ V}$, $V_O = 0.1\text{ to }4.4\text{ V}$	100	115		
		$T_A = -40\text{ to }+125\text{ }^\circ\text{C}$		100		
FREQUENCY RESPONSE						
Gain bandwidth product	GBW			22		MHz
Slew rate	SR	$V_S = 30\text{ V}$, $G = +1$, 8 V step		17		$\text{V}/\mu\text{s}$
Total harmonic distortion + noise	THD+N	$G = +1$, $f = 1\text{ kHz}$, $V_O = 3\text{ V}_{RMS}$		0.0001		%
Settling time	t_s	To 0.1%, $V_S = 40\text{ V}$, $G = +1$, 5 V step		0.9		μs
		To 0.01%, $V_S = 40\text{ V}$, $G = +1$, 5 V step		2		
Overload recovery time	t_{OR}	$V_{IN} \times \text{Gain} > V_S$		0.3		μs

48V, 22MHz, Low Noise, Precision Operational Amplifiers

Electrical Characteristics(continued)

$V_S = 4.5\text{ V to }48\text{ V}$, $T_A = +25\text{ }^\circ\text{C}$, $V_{CM} = V_{OUT} = V_S / 2$, and $R_L = 10\text{ k}\Omega$ connected to $V_S / 2$, unless otherwise noted. Boldface limits apply over the specified temperature range, $T_A = -40\text{ }^\circ\text{C to }+125\text{ }^\circ\text{C}$.

Parameter	Symbol	Conditions	Min.	Typ.	Max.	Unit
OUTPUT						
High output voltage swing	V_{OH}	$V_S = \pm 24\text{ V}$, $R_L = 10\text{ k}\Omega$	$V_{S+} - 114$	$V_{S+} - 70$		mV
		$V_S = \pm 24\text{ V}$, $R_L = 2\text{ k}\Omega$	$V_{S+} - 674$	$V_{S+} - 300$		
Low output voltage	V_{OL}	$V_S = \pm 24\text{ V}$, $R_L = 10\text{ k}\Omega$		$V_{S-} + 55$	$V_{S-} + 105$	mV
		$V_S = \pm 24\text{ V}$, $R_L = 2\text{ k}\Omega$		$V_{S-} + 280$	$V_{S-} + 614$	
Short-circuit current	I_{sc}			± 35		mA
POWER SUPPLY						
Operating supply voltage	V_S	$T_A = -40\text{ to }+125\text{ }^\circ\text{C}$	4.5		48	V
Quiescent current (per amplifier)	I_q	$V_S = 4.5\text{ V}$		2.6		mA
		$V_S = 48\text{ V}$		4.4		
THERMAL CHARACTERISTICS						
Operating temperature range	T_A		-40		+125	$^\circ\text{C}$
Package Thermal Resistance	θ_{JA}	SOT23-5L		190		$^\circ\text{C/W}$
		EMSOP-8L		60		
		ESOP-8L		50		
		ETSSOP-14L		55		
		SOIC-14L		115		

Typical Performance Characteristics

At $T_A = +25^\circ\text{C}$, $V_{CM} = V_S / 2$, and $R_L = 10\text{ k}\Omega$ connected to $V_S / 2$, unless otherwise noted.

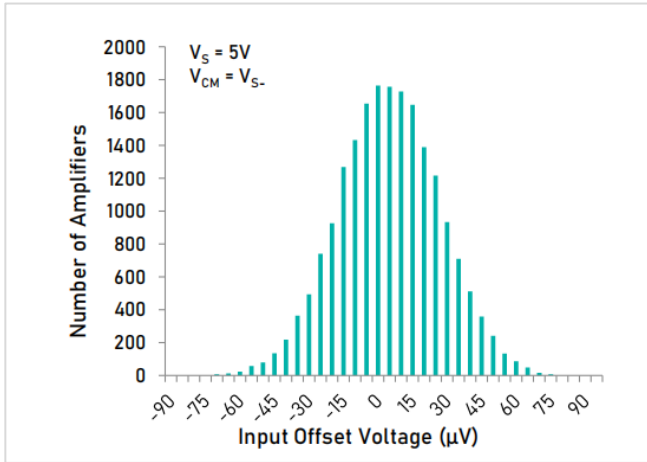

Offset Voltage Production Distribution

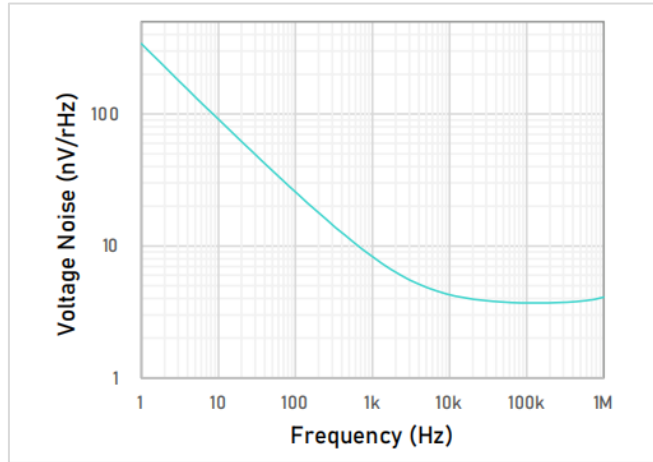

Input Voltage Noise Spectral Density as a function of Frequency

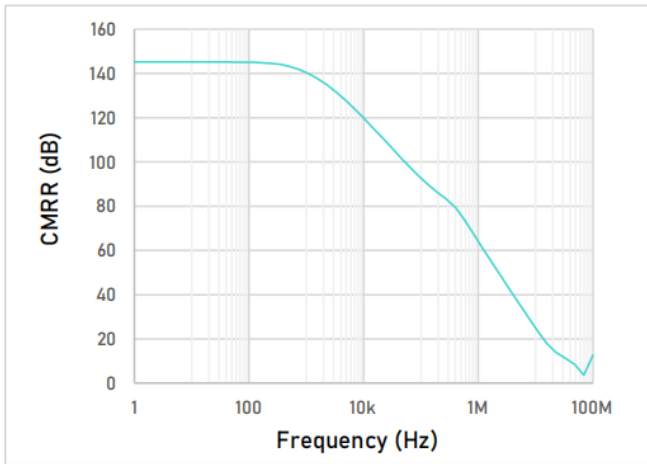

CMRR as a function of Frequency

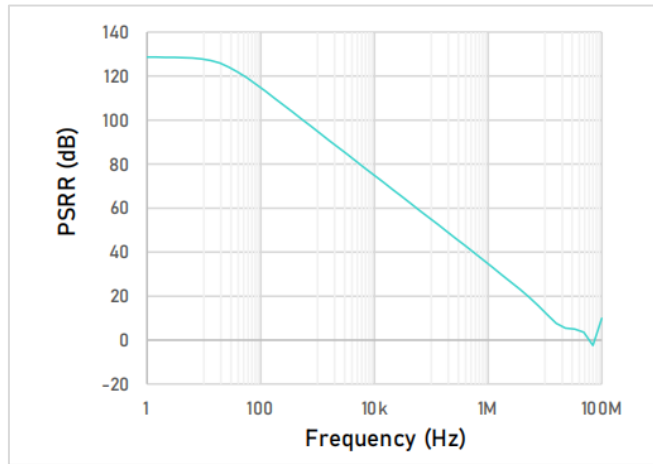

PSRR as a function of Frequency

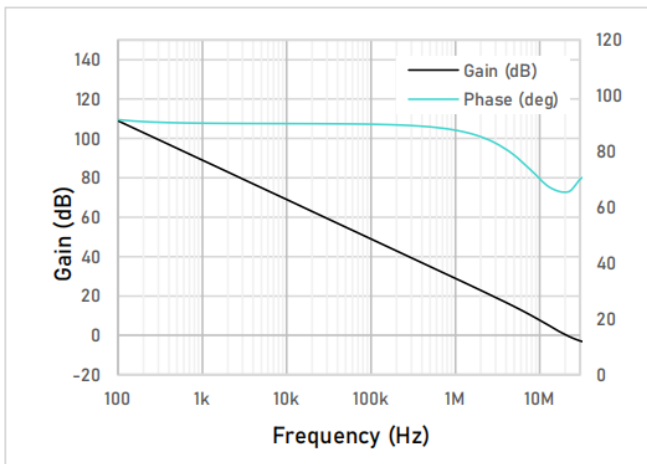

Open-loop Gain and Phase as a function of Frequency

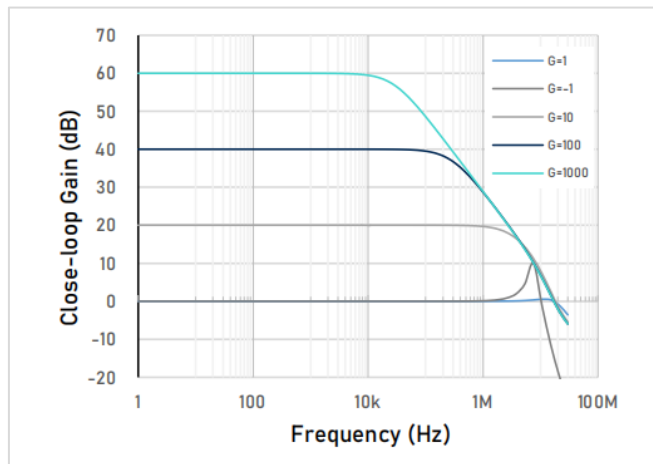

Close-loop Gain as a function of Frequency

Typical Performance Characteristics (Continued)

At $T_A = +25^\circ\text{C}$, $V_{CM} = V_S / 2$, and $R_L = 10\text{ k}\Omega$ connected to $V_S / 2$, unless otherwise noted.

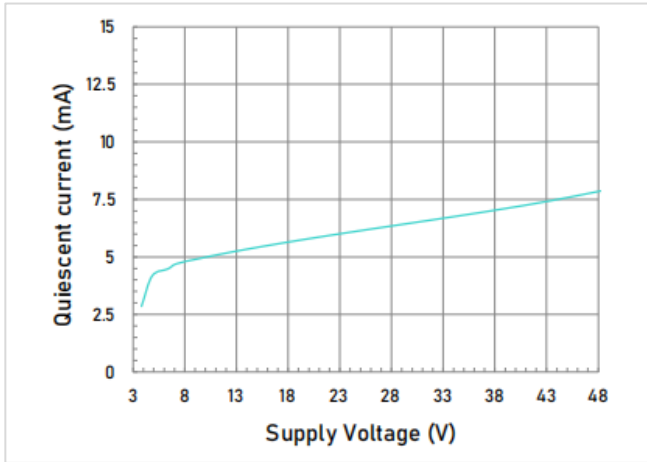

Quiescent Current as a function of Supply Voltage

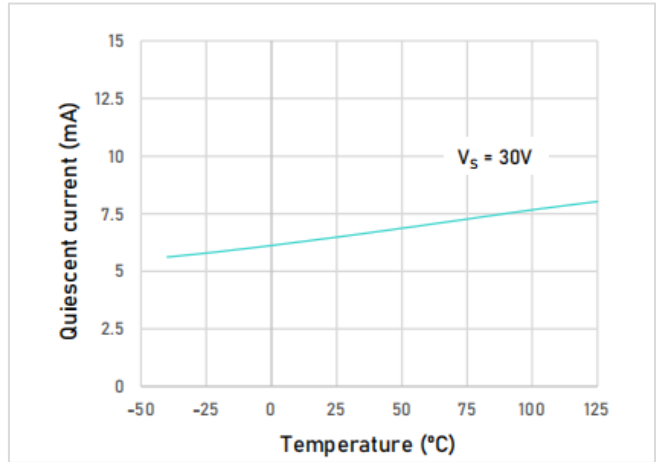

Quiescent Current as a function of Temperature

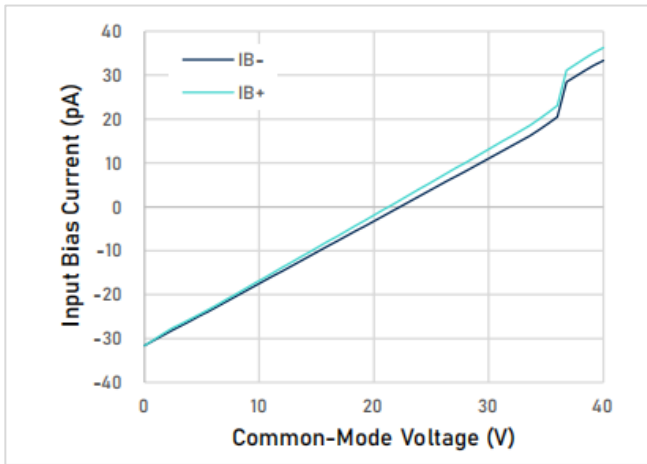

Bias Current as a function of Common-Mode Voltage

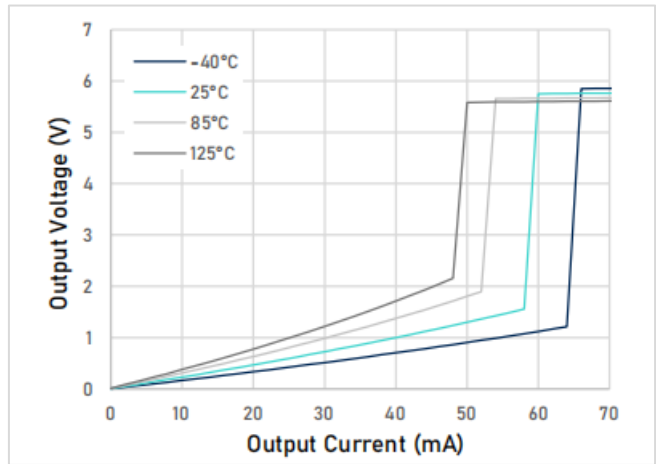

Output Voltage Swing as a function of Output Current (Sinking, $V_S = 40\text{ V}$)

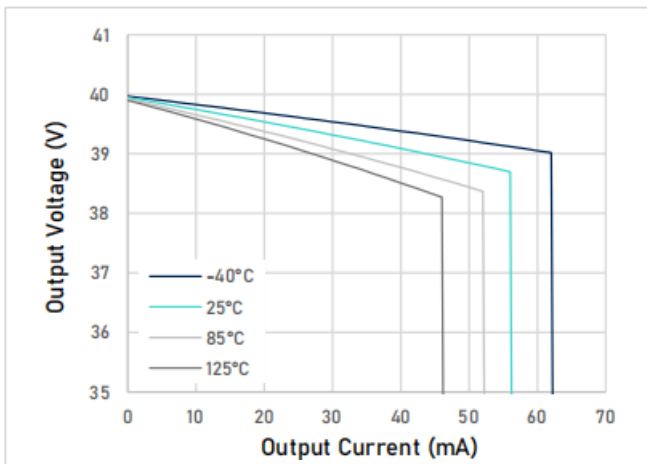

Output Voltage Swing as a function of Output Current (Sourcing, $V_S = 40\text{ V}$)

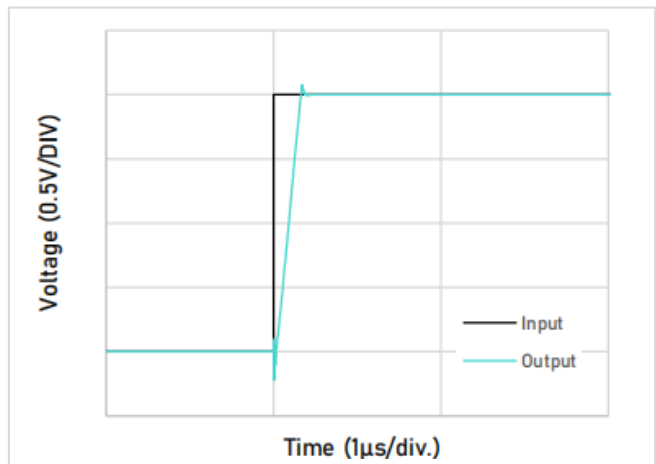

Large-Signal Step Response (Rising)

Typical Performance Characteristics (Continued)

At $T_A = +25^\circ\text{C}$, $V_{CM} = V_S / 2$, and $R_L = 10\text{ k}\Omega$ connected to $V_S / 2$, unless otherwise noted.

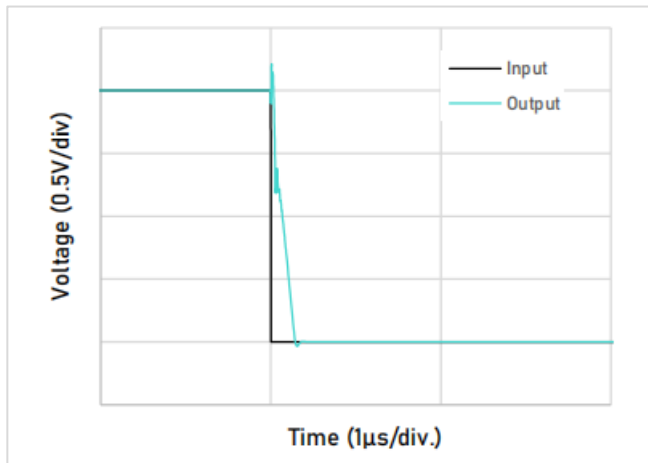

Large-Signal Step Response (Failing)

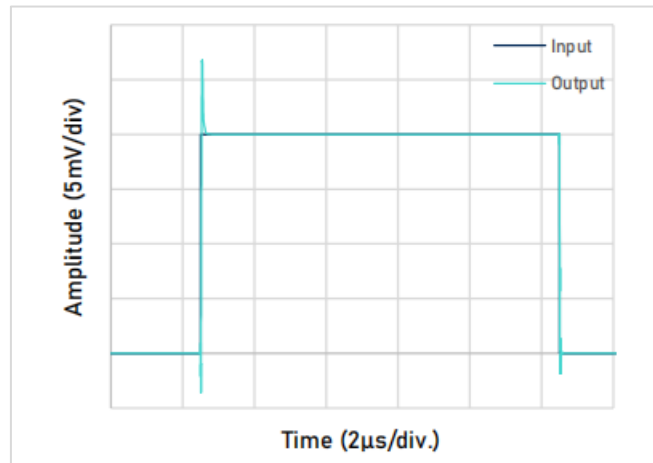

Small-Signal Step Response

Tape and Reel Information

REEL DIMENSIONS

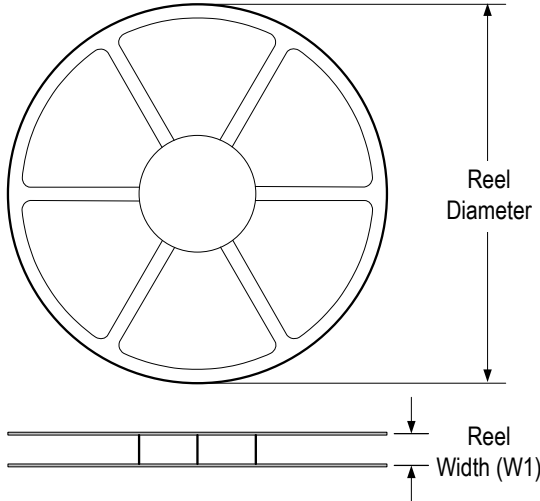

TAPE DIMENSIONS

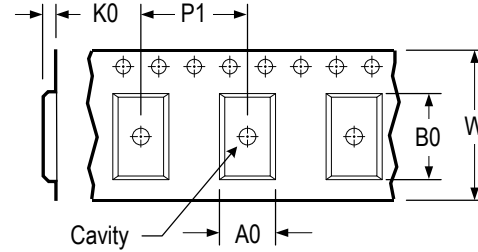

A0	Dimension designed to accommodate the component width
B0	Dimension designed to accommodate the component length
K0	Dimension designed to accommodate the component thickness
W	Overall width of the carrier tape
P1	Pitch between successive cavity centers

QUADRANT ASSIGNMENTS FOR PIN 1 ORIENTATION IN TAPE

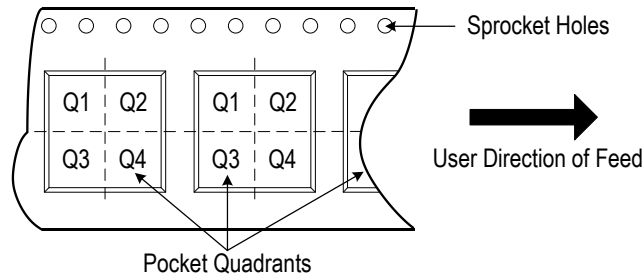

* All dimensions are nominal

Device	Package Type	Pins	SPQ	Reel Diameter (mm)	Reel Width W1 (mm)	A0 (mm)	B0 (mm)	K0 (mm)	P1 (mm)	W (mm)	Pin 1 Quadrant
LTA8091EXT5/R6	SOT23	5	3 000	178	9.5	3.3	3.2	1.5	4.0	8.0	Q3
LTA8091EXS8/R8	ESOP	8	4 000	330	12.5	6.6	5.3	2.0	8.0	12.0	Q1
LTA8092EXS8/R8	ESOP	8	4 000	330	12.5	6.6	5.3	2.0	8.0	12.0	Q1
LTA8092EXV8/R6	EMSOP	8	3 000	330	12.5	5.0	3.5	2.0	8.0	12.0	Q1
LTA8092EXF8/R10	DFN3x3	8	5 000	330	12.5	3.3	3.3	1.1	8.0	12.0	Q1
LTA8092EXS14/R	SOIC	14	2 500	330	12.5	6.5	9.5	2.0	8.0	16.0	Q1
LTA8092EXT14/R6	ETSSOP	14	3 000	330	12.5	6.9	5.5	1.3	8.0	16.0	Q1

Package Outlines

DIMENSIONS, SOT23-5L

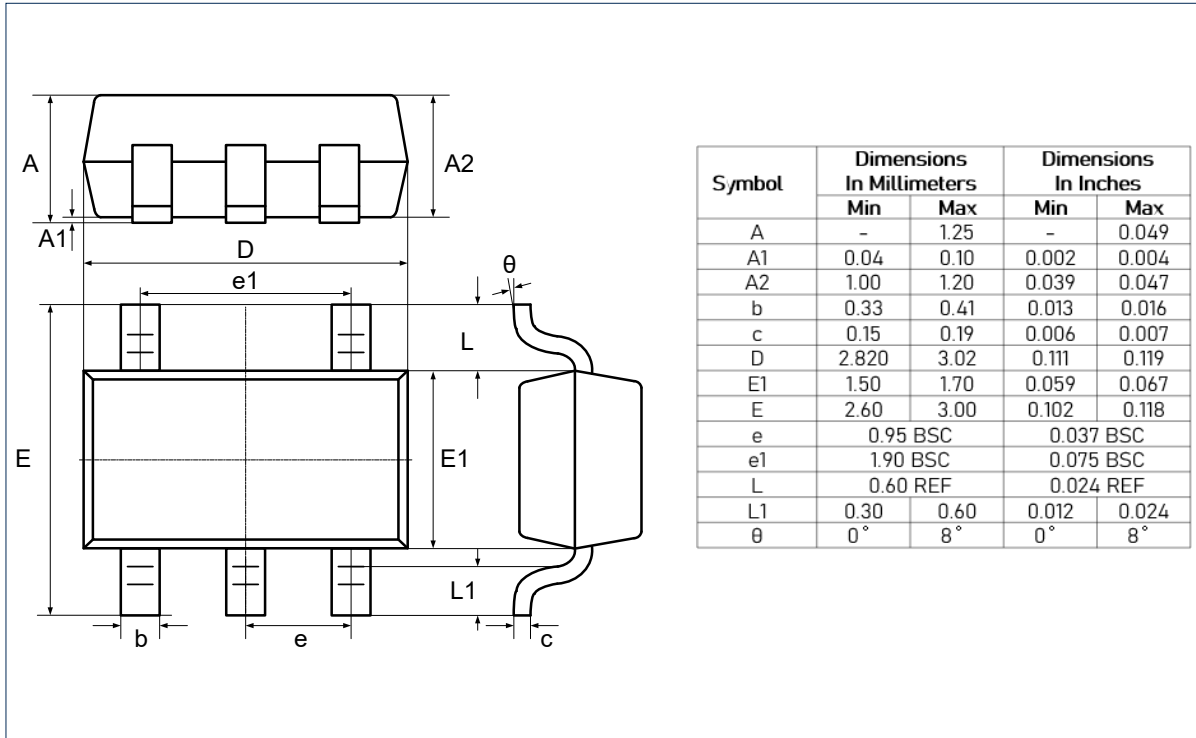

RECOMMENDED SOLDERING FOOTPRINT, SOT23-5L

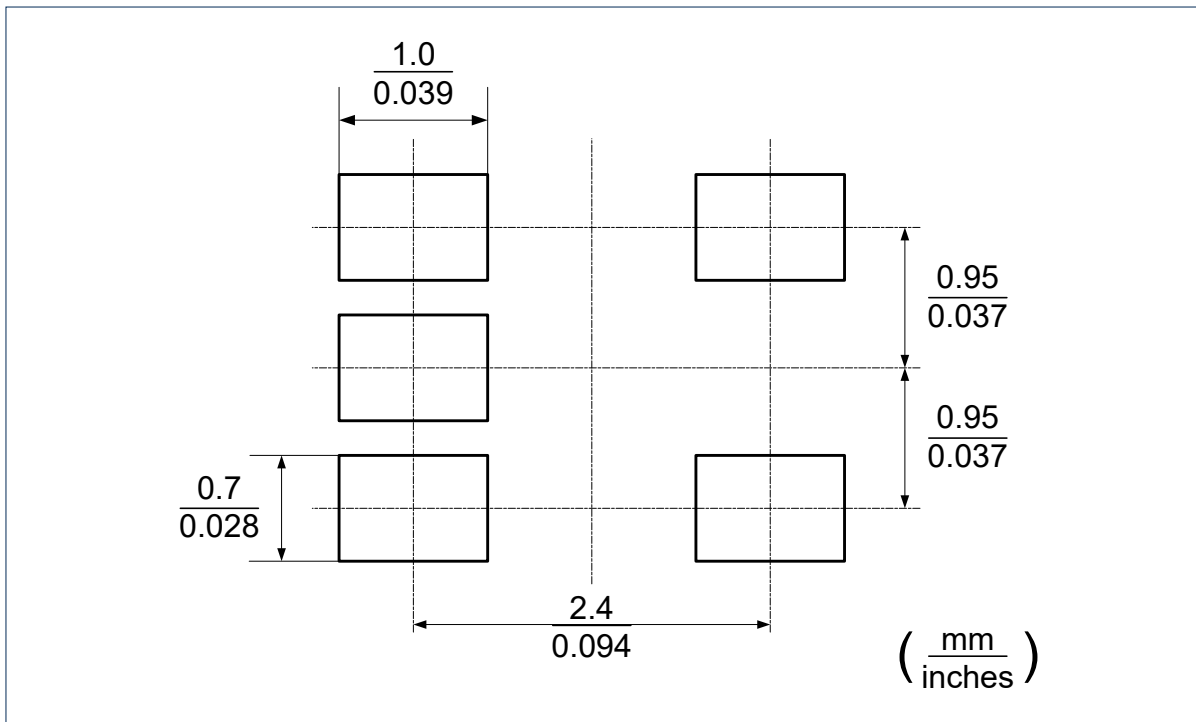

Package Outlines (Continued)

DIMENSIONS, ESOP-8L

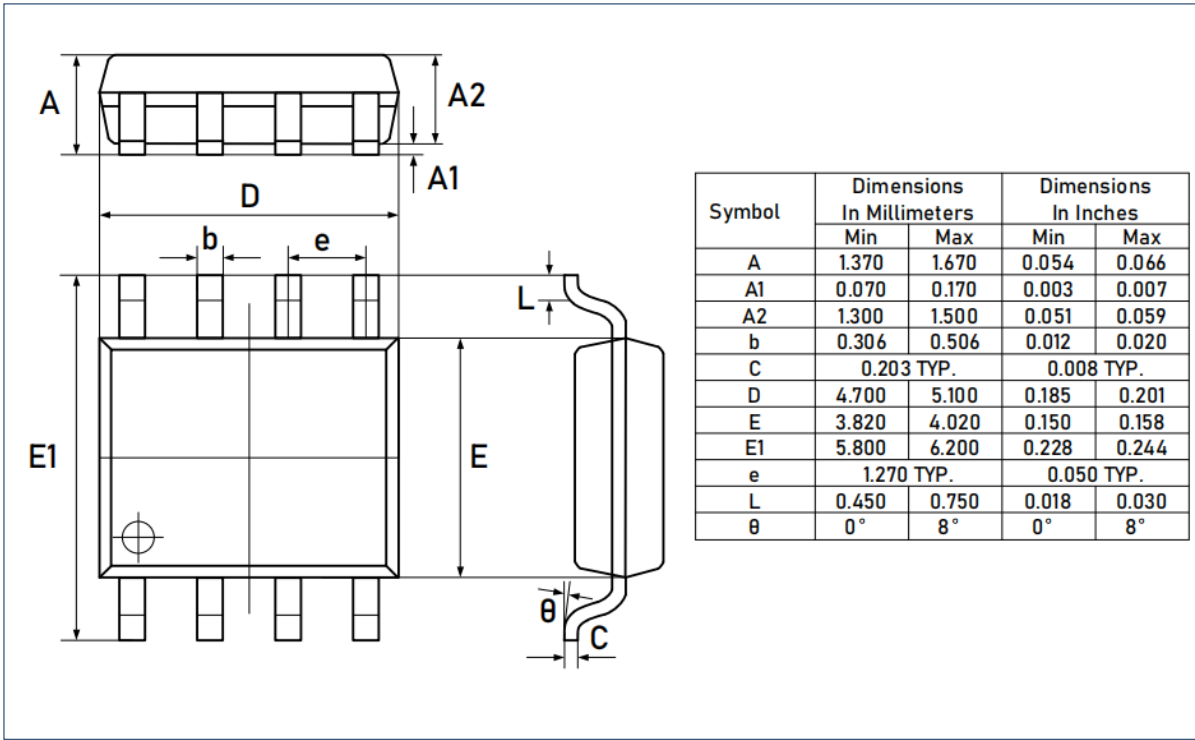

RECOMMENDED SOLDERING FOOTPRINT, ESOP-8L

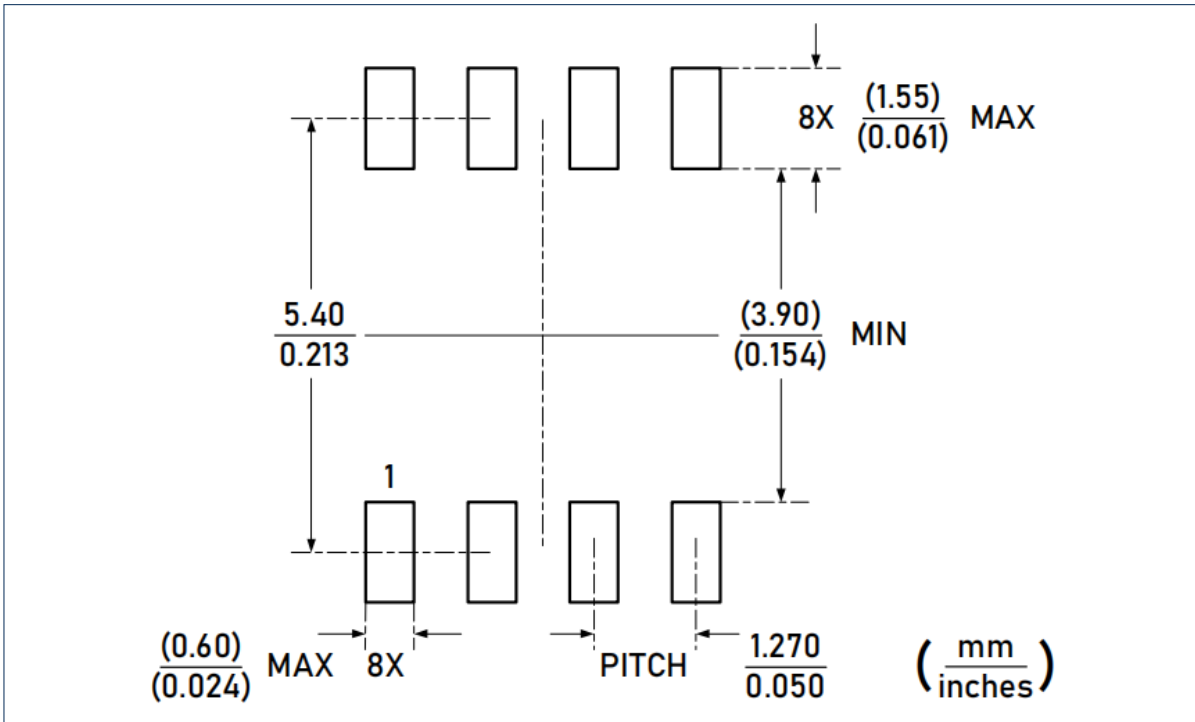

Package Outlines (Continued)

DIMENSIONS, EMSOP-8L

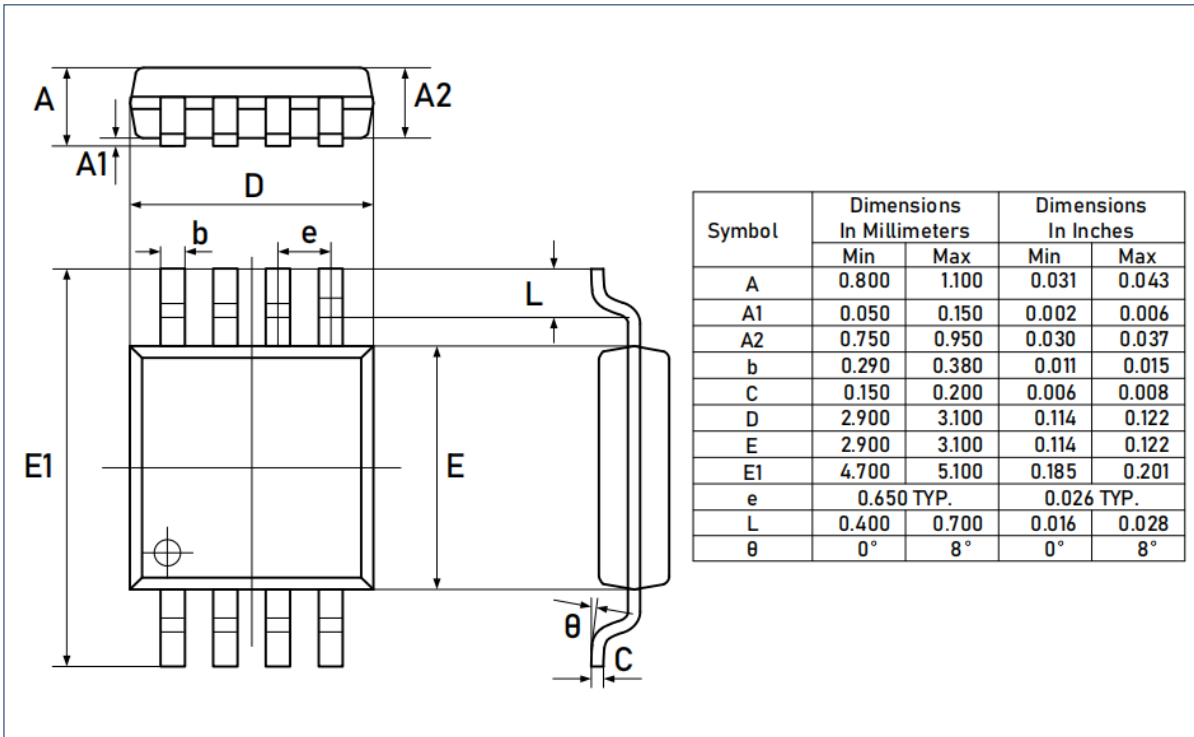

RECOMMENDED SOLDERING FOOTPRINT, EMSOP-8L

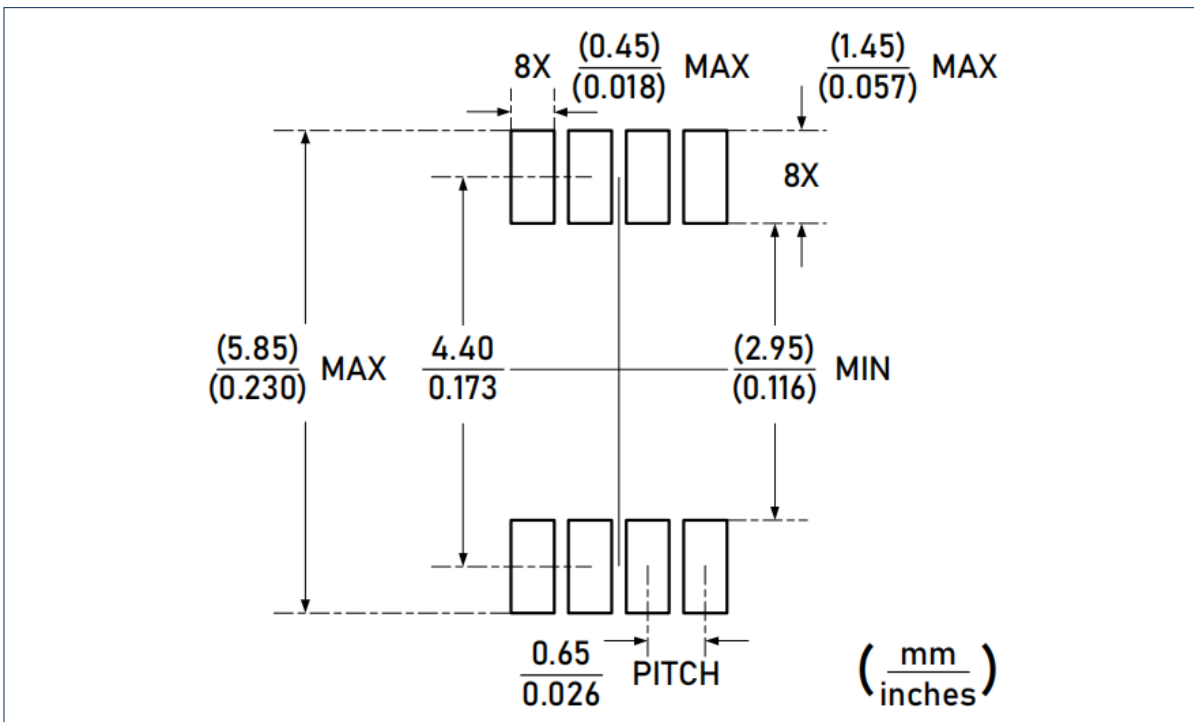

Package Outlines (Continued)

DIMENSIONS, DFN3x3-8L

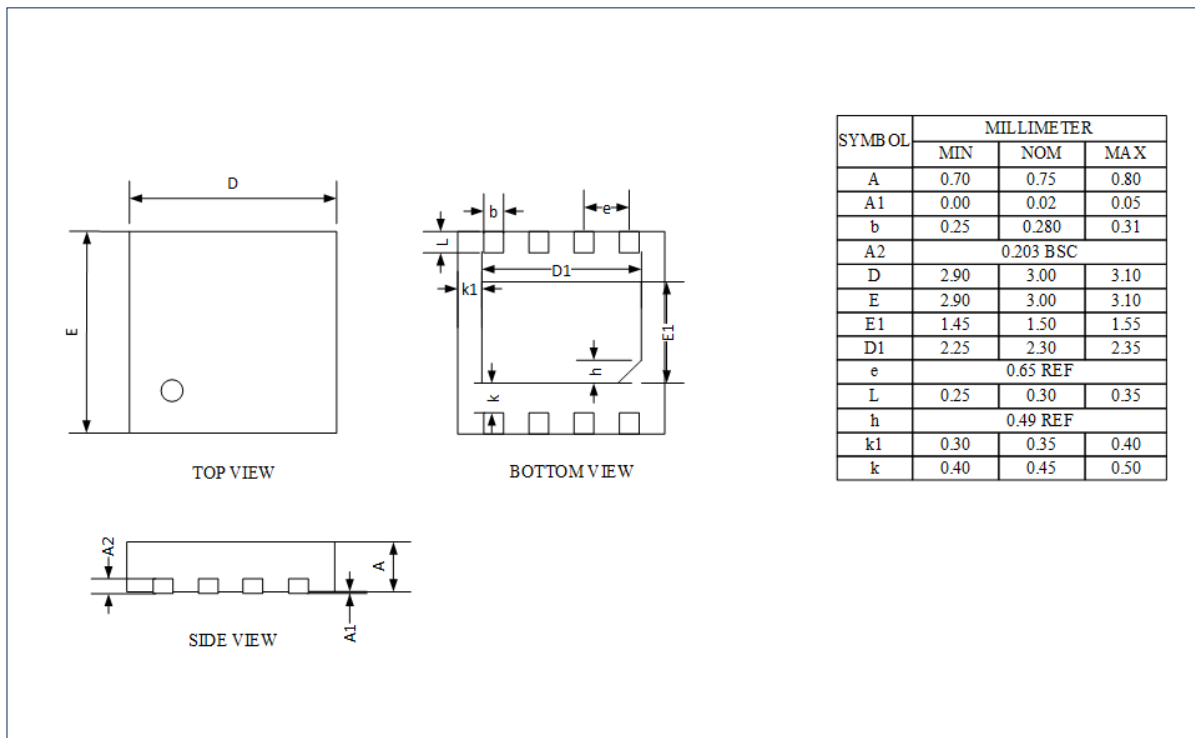

Package Outlines (Continued)

DIMENSIONS, SOIC-14L

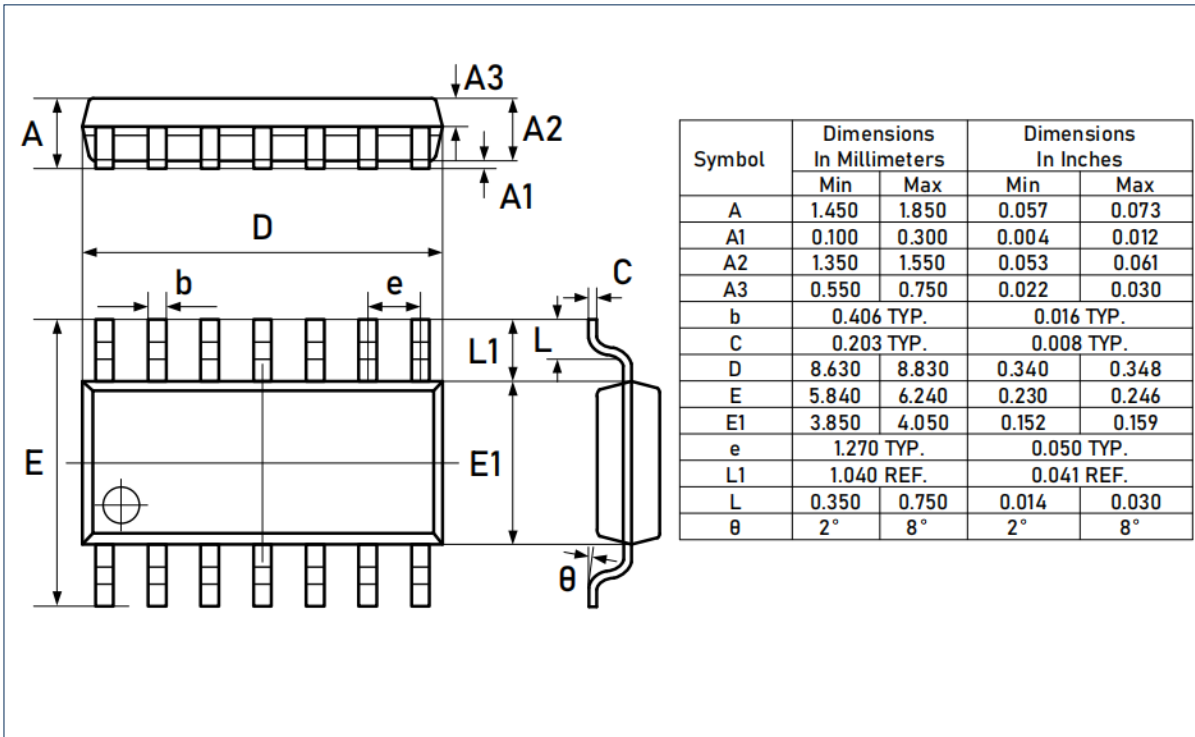

RECOMMENDED SOLDERING FOOTPRINT, SOIC-14L

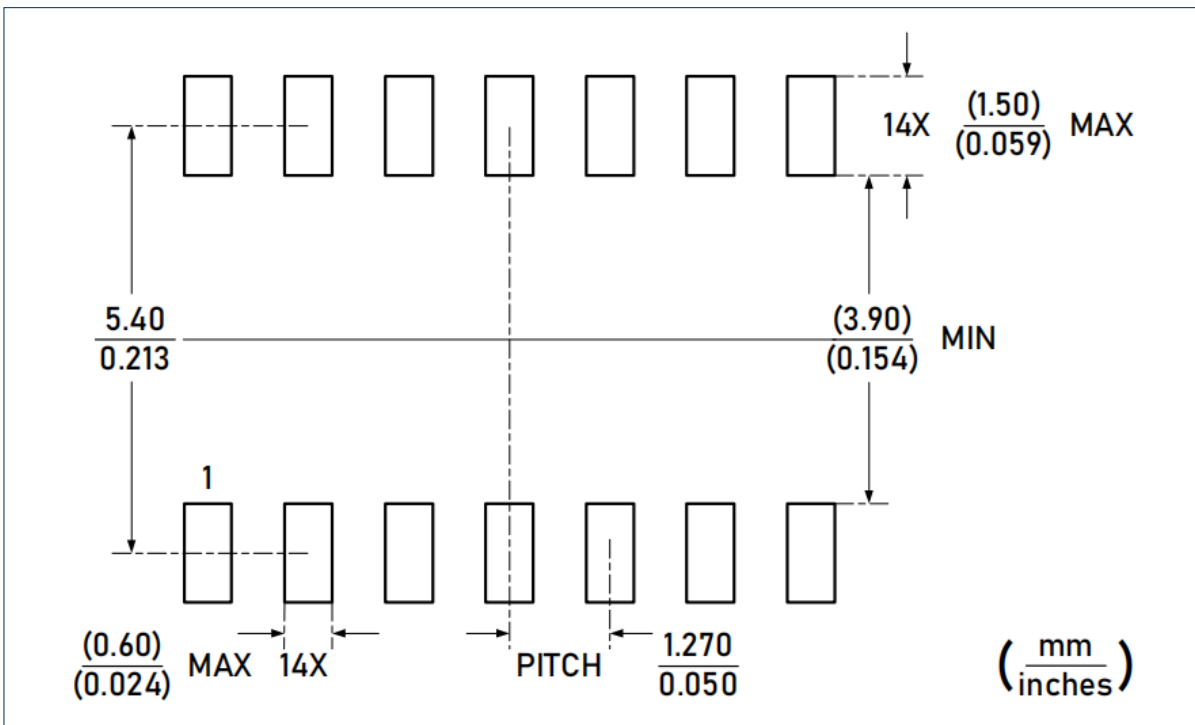

Package Outlines (Continued)

DIMENSIONS, ETSSOP-14L

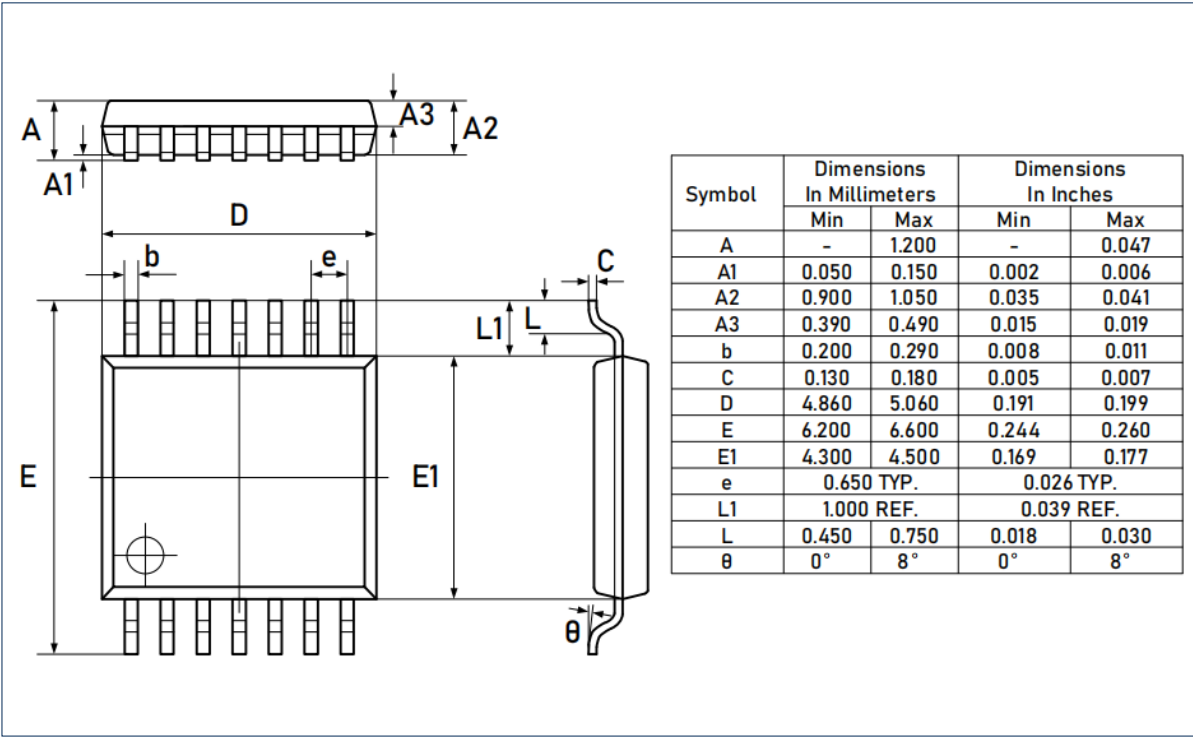

RECOMMENDED SOLDERING FOOTPRINT, ETSSOP-14L

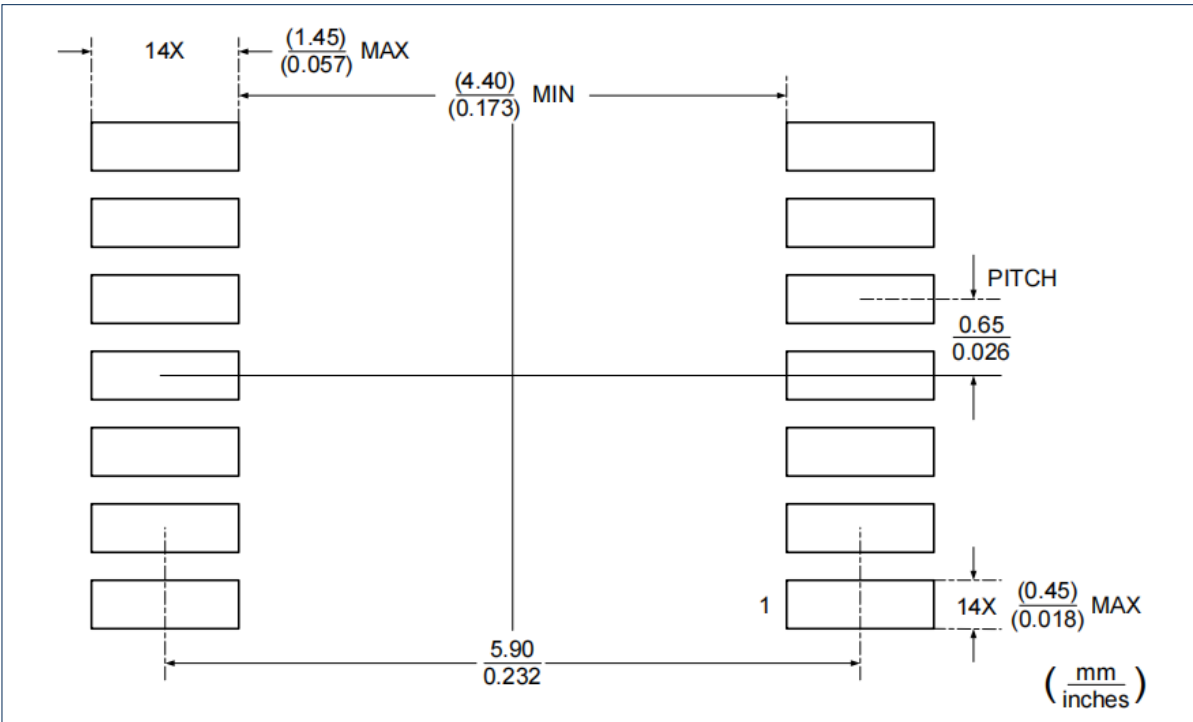

Important Notice

Linearin is a global fabless semiconductor company specializing in advanced high-performance high-quality analog/mixed-signal IC products and sensor solutions. The company is devoted to the innovation of high performance, analog-intensive sensor front-end products and modular sensor solutions, applied in multi-market of medical & wearable devices, smart home, sensing of IoT, intelligent industrial & smart factory (industrial 4.0), and automotives. Linearin's product families include widely-used standard catalog products, solution-based application specific standard products (ASSPs) and sensor modules that help customers achieve faster time-to-market products. Go to <http://www.linearin.com> for a complete list of Linearin product families.

For additional product information, or full data sheet, please contact with the Linearin's Sales Department or Representatives.