

General Description

The ULN2003A is high-voltage high-current Darlington transistor arrays each containing seven open collector common emitter pairs. Each pair is rated at 500mA. Suppression diodes are included for inductive load driving, the inputs and outputs are pinned in opposition to simplify board layout. These devices are capable of driving a wide range of loads including solenoids, relays, DC motors, LED displays, filament lamps, thermal print-heads and high-power buffers. The ULN2003A is available in both a small outline 16-pin package(SOIC-16L and TSSOP-16L).

Features

- 500-mA-Rated Collector Current(single output)
- High-Voltage Outputs: 50V
- Output Clamp Diodes
- Inputs Compatible With Various Types of Logic
- Relay-Driver Applications

Pin Assignments

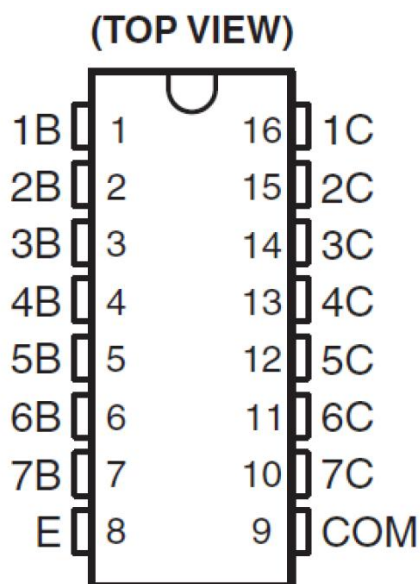
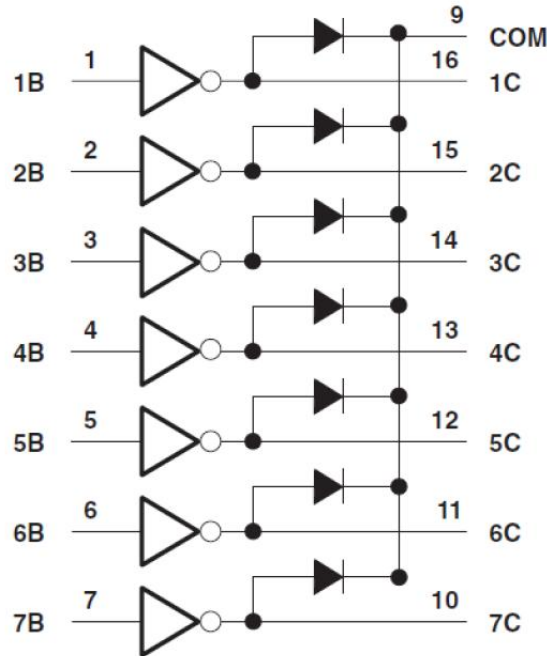

Table of Content

General Description	1
Features	1
Pin Assignments	1
Table of Content	2
General Description	3
Pin Descriptions.....	3
Functional Block Diagram	4
Ordering Information	4
Absolute Maximum Ratings	5
ESD Rating	5
Recommended Operating Conditions	5
Electrical Characteristics	6
Part measurement information	7
Typical Characteristics	8
Tape and Reel Information	9
Outlines Dimensions	10
Important Notice	11

General Description

LOGIC DIAGRAM



Pin Descriptions

Pin Number	Pin Name	Function
1	1B	Input pair1
2	2B	Input pair1
3	3B	Input pair1
4	4B	Input pair1
5	5B	Input pair1
6	6B	Input pair1
7	7B	Input pair1
8	E	Common Emitter (ground)
9	COM	Common Clamp Diodes
10	7C	Output pair7
11	6C	Output pair6
12	5C	Output pair5
13	4C	Output pair4
14	3C	Output pair3
15	2C	Output pair2
16	1C	Output pair1

Functional Block Diagram

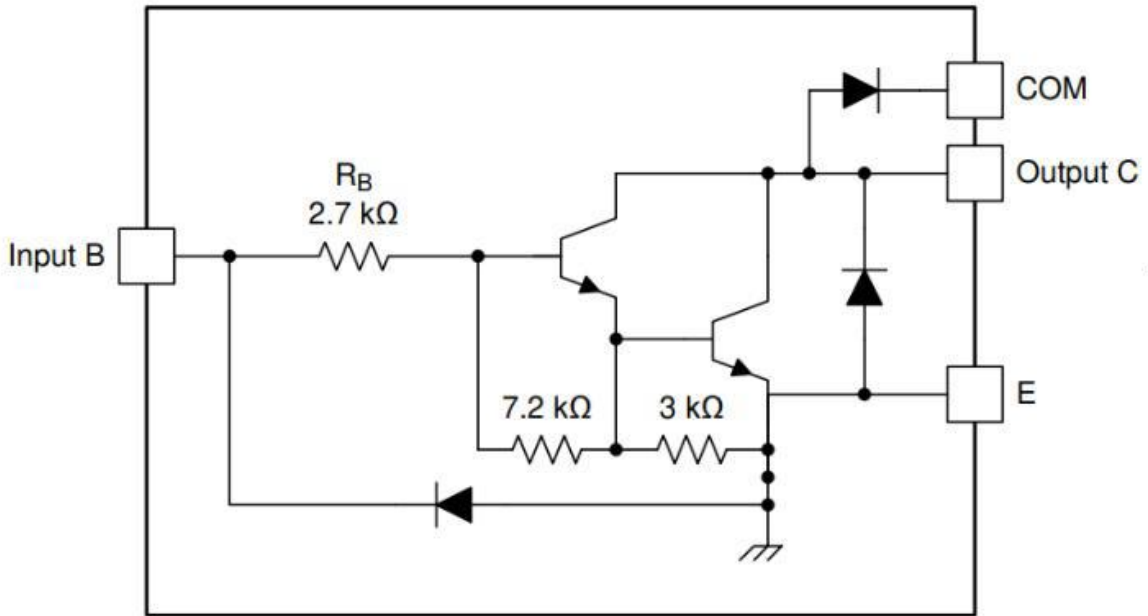

Note: All resistor values shown are nominal.

The collector-emitter diode is a parasitic structure and should not be used to conduct current. If the collector(s) go below ground an external Schottky diode should be added to clamp negative undershoots.

Ordering Information

Type Number	Package Name	Package Quantity	Mark Code
ULN2003AXS16/R5	SOIC-16L	2 500, Tape & Reel	A2003
ULN2003AXT16/R6	TSSOP-16L	3 000, Tape & Reel	A2003

Absolute Maximum Ratings

$T_A=25^{\circ}\text{C}$ free -air temperature (unless otherwise noted)

Symbol	Parameter	Min	Max	Unit
V_S	Collector to emitter voltage		50	V
V_R	Clamp diode reverse voltage		50	V
V_I	Input voltage		30	V
I_{CP}	Peak collector current		500	mA
I_{ok}	Output clamp current		500	mA
I_{TE}	Total emitter-terminal current		-2.5	A
T_A	Operating free-air temperature range	-40	+105	$^{\circ}\text{C}$
θ_{JA}	Thermal Resistance Junction-to-Ambient		63	$^{\circ}\text{C}/\text{W}$
θ_{Jc}	Thermal Resistance Junction-to-Case		12	$^{\circ}\text{C}/\text{W}$
T_J	Operating virtual junction temperature		+150	$^{\circ}\text{C}$
T_{STG}	Storage temperature range	-65	+150	$^{\circ}\text{C}$

ESD Ratings

Parameter	Value	Unit
Human body model (HBM), per ANSI/ESDA/JEDEC JS-001	$\pm 3\ 000$	V
Charged device model (CDM), per ANSI/ESDA/JEDEC JS-002	$\pm 2\ 000$	V

Recommended Operating Conditions

Symbol	Parameter	Min	Max	Unit
V_S	Collector to Emitter voltage		50	V
T_A	Operating Ambient Temperature	-40	+105	$^{\circ}\text{C}$

Electrical Characteristics

(T_A = 25°C, unless otherwise specified.)

Parameter		Test Figure	Test Conditions		ULN2003A			Unit
					MIN	TYP	MAX	
V _{I(on)}	On-state input voltage	Figure 6	V _{CE} =2V	I _C =200mA			2.4	V
				I _C =250mA			2.7	
				I _C =300mA			3	
V _{CE(sat)}	Collector-emitter saturation voltage	Figure 5	I _I =250 μA, I _C =100mA		0.9	1.1	V	
			I _I =350 μA, I _C =200mA		1	1.3		
			I _I =500 μA, I _C =350mA		1.2	1.6		
I _{CEX}	Collector cutoff current	Figure 1	V _{CE} =50 V, I _I =0			50	μA	
		Figure 2	V _{CE} =50V, T _A =+105°C, I _I =0			100		
V _F	Clamp forward voltage	Figure 8	I _F =350 mA		1.7	2	V	
I _{I(off)}	Off-state input current	Figure 3	V _{CE} =50 V, I _C =500μA	50	65		μA	
I _I	Input current	Figure 4	V _I =3.85V		0.93	1.35	mA	
I _R	Clamp reverse current	Figure 7	V _R =50V			50	μA	
				T _A =70°C				100
C _I	Input capacitance		V _I =0, f=1MHz		15	25	pF	
h _{EF}	DC amplification factor		V _{CE} =2.0V, I _C =350mA	1 000				
t _{ON}	Conduction delay time		T _A =25°C, V _L =12V, R _L =45Ω, C _L =15pF		0.2	1	μs	
			T _A =-40°C to 85°C, V _L =12V, R _L =45Ω		0.25	1		
t _{OFF}	Turn off delay time		T _A =25°C, V _L =12V, R _L =45Ω, C _L =15pF		0.3	1	μs	
			T _A =-40°C to 85°C, V _L =12V, R _L =45Ω		0.35	1		

Part measurement information

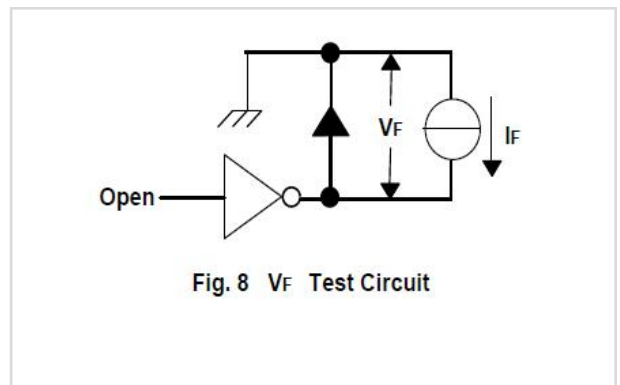
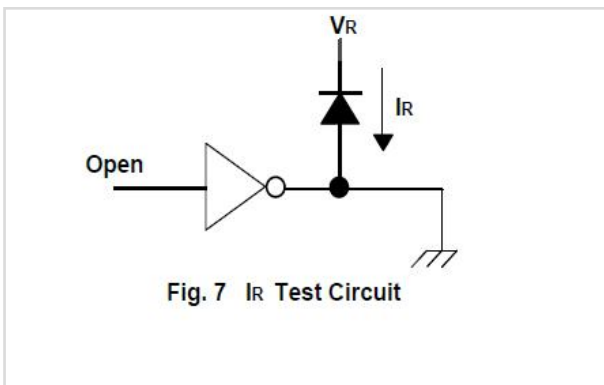
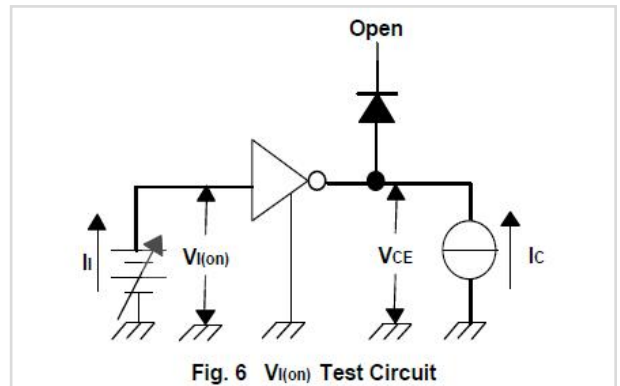
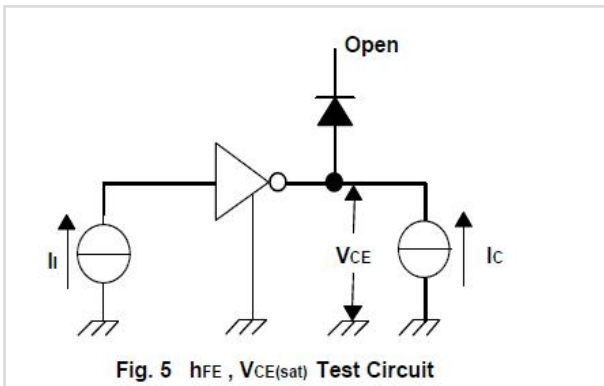
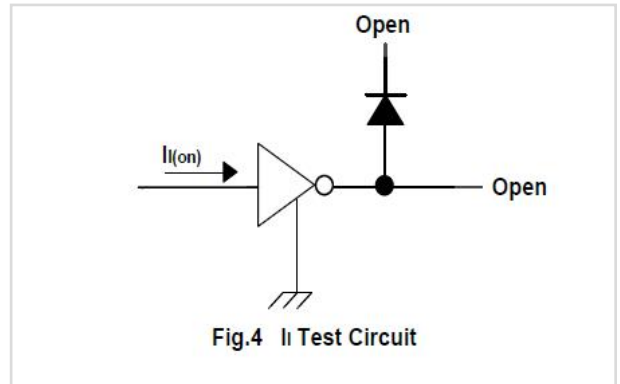
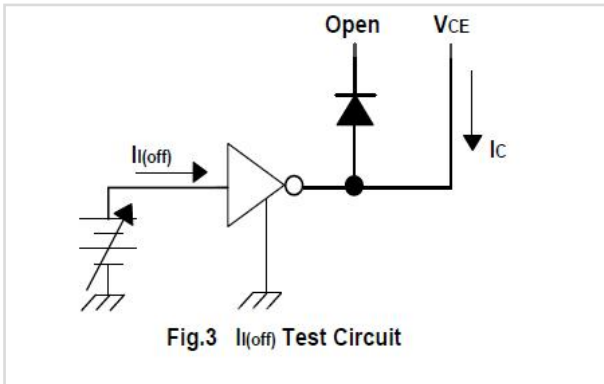
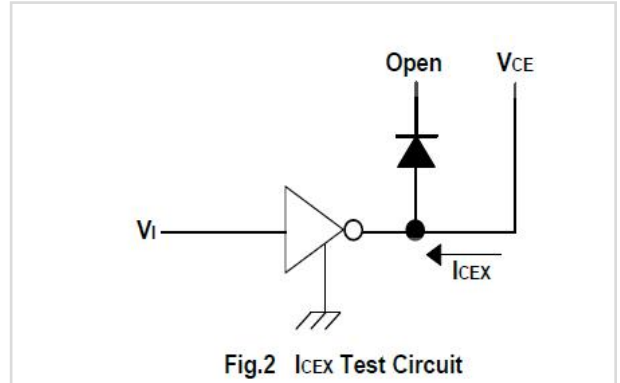
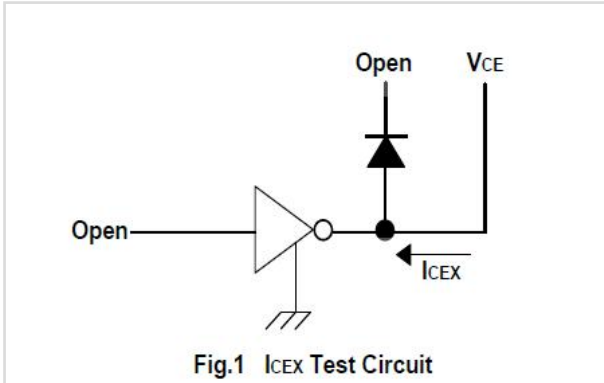

CAUTION: These devices are sensitive to electrostatic discharge; follow proper IC Handling Procedures.
 Linearin and designs are registered trademarks of Linearin Technology Corporation.
 © Copyright Linearin Technology Corporation. All Rights Reserved.
 All other trademarks mentioned are the property of their respective owners.

Typical Characteristics

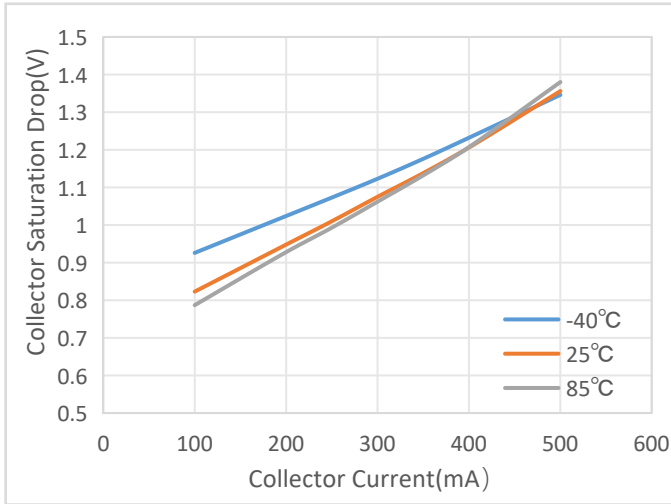

Collector Saturation Voltage Drop vs Collector Current

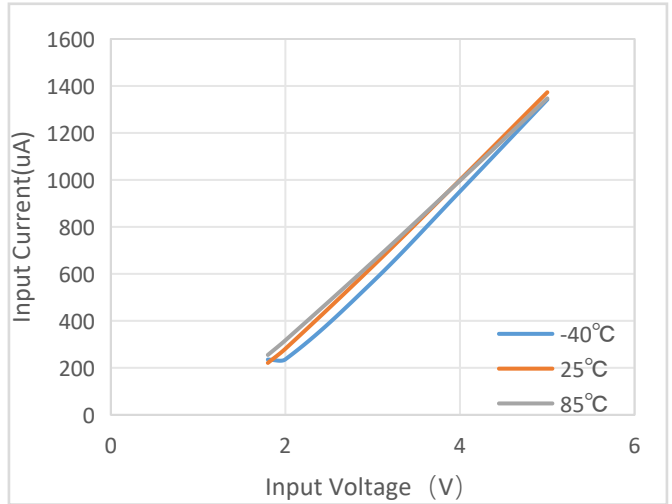

Input Current vs Input Voltage

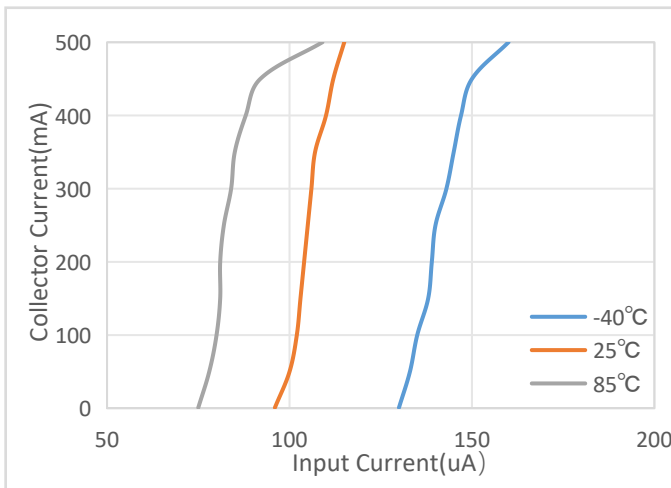

Collector Current vs Input Current

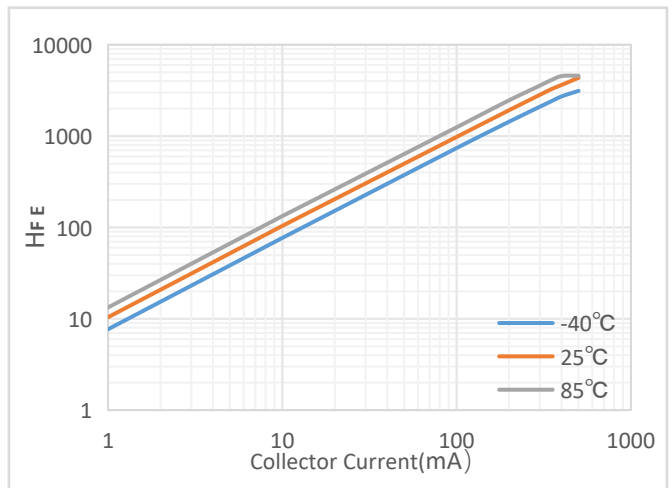

H_{FE} vs collector current

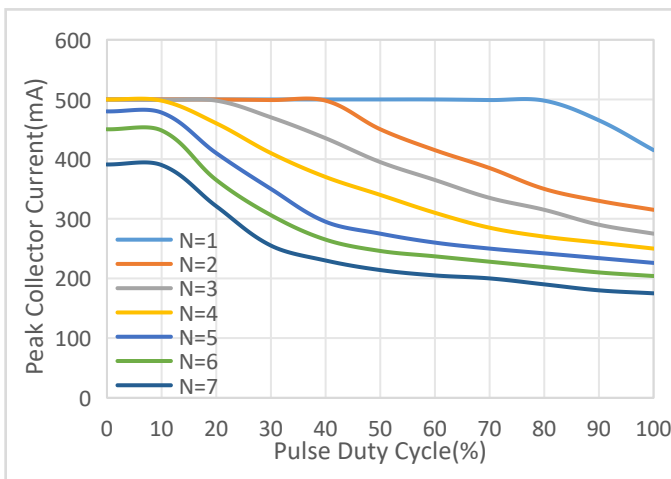

Peak Collector Current vs Pulse Duty Cycle

CAUTION: These devices are sensitive to electrostatic discharge; follow proper IC Handling Procedures.
 Linearin and designs are registered trademarks of Linearin Technology Corporation.
 © Copyright Linearin Technology Corporation. All Rights Reserved.
 All other trademarks mentioned are the property of their respective owners.



Tape and Reel Information

REEL DIMENSIONS

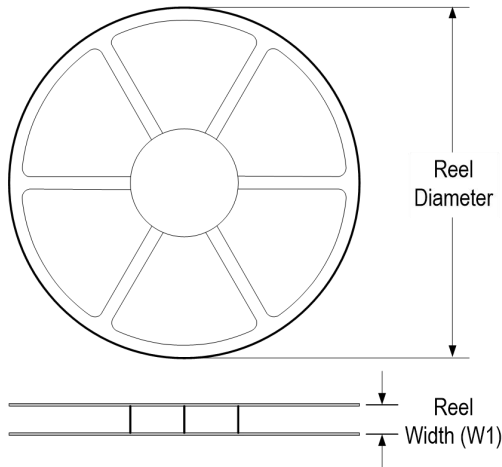

TAPE DIMENSIONS

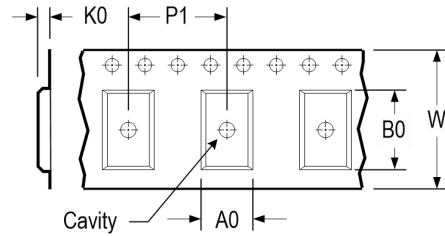

A0	Dimension designed to accommodate the component width
B0	Dimension designed to accommodate the component length
K0	Dimension designed to accommodate the component thickness
W	Overall width of the carrier tape
P1	Pitch between successive cavity centers

QUADRANT ASSIGNMENTS FOR PIN 1 ORIENTATION IN TAPE

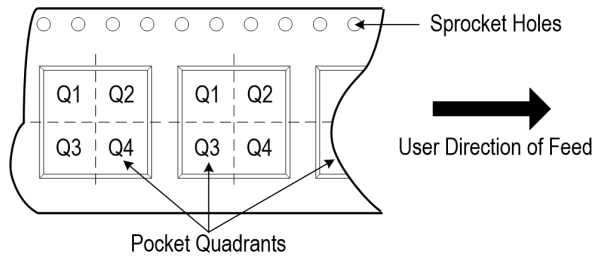

* All dimensions are nominal

Device	Package Type	Pins	SPQ	Reel Diameter (mm)	Reel Width W1 (mm)	A0 (mm)	B0 (mm)	K0 (mm)	P1 (mm)	W (mm)	Pin 1 Quadrant
ULN2003AXS16/R5	SOIC	16	2 500	330	16.5	6.6	10.4	2.0	8.0	16.0	Q1
ULN2003AXT16/R6	TSSOP	16	3 000	330	16.5	6.9	5.6	1.6	8.0	16.0	Q1

Outline Dimensions

DIMENSIONS, SOIC-16L

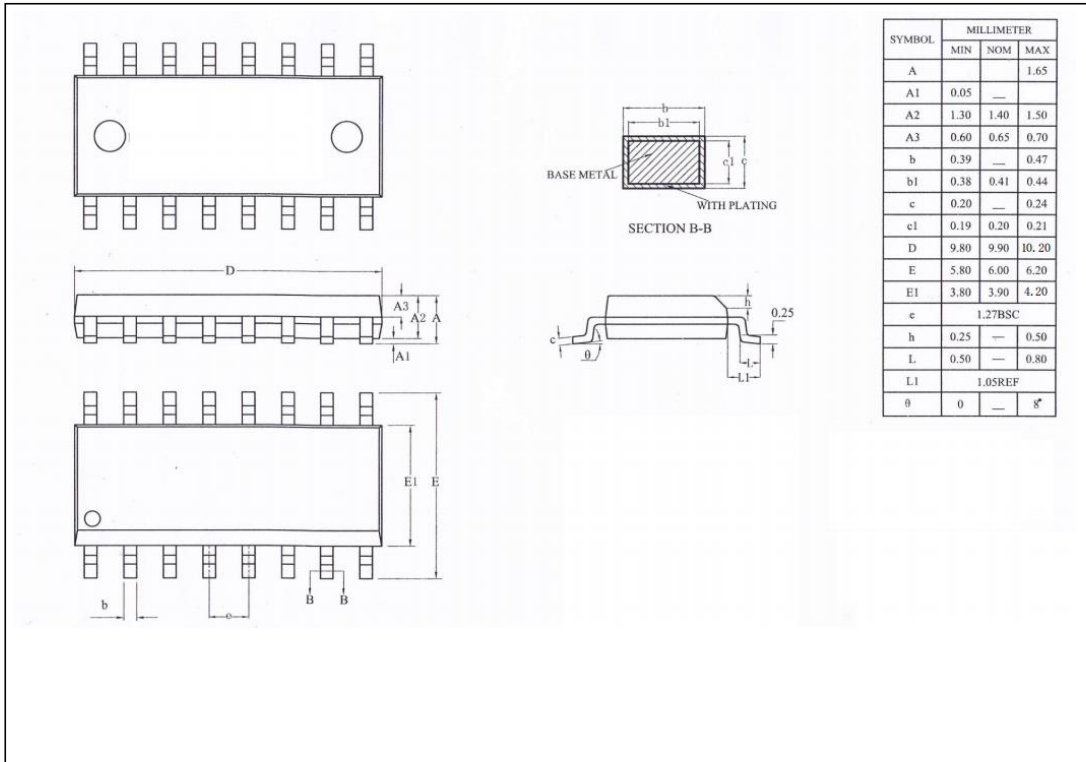

DIMENSIONS, TSSOP-16L

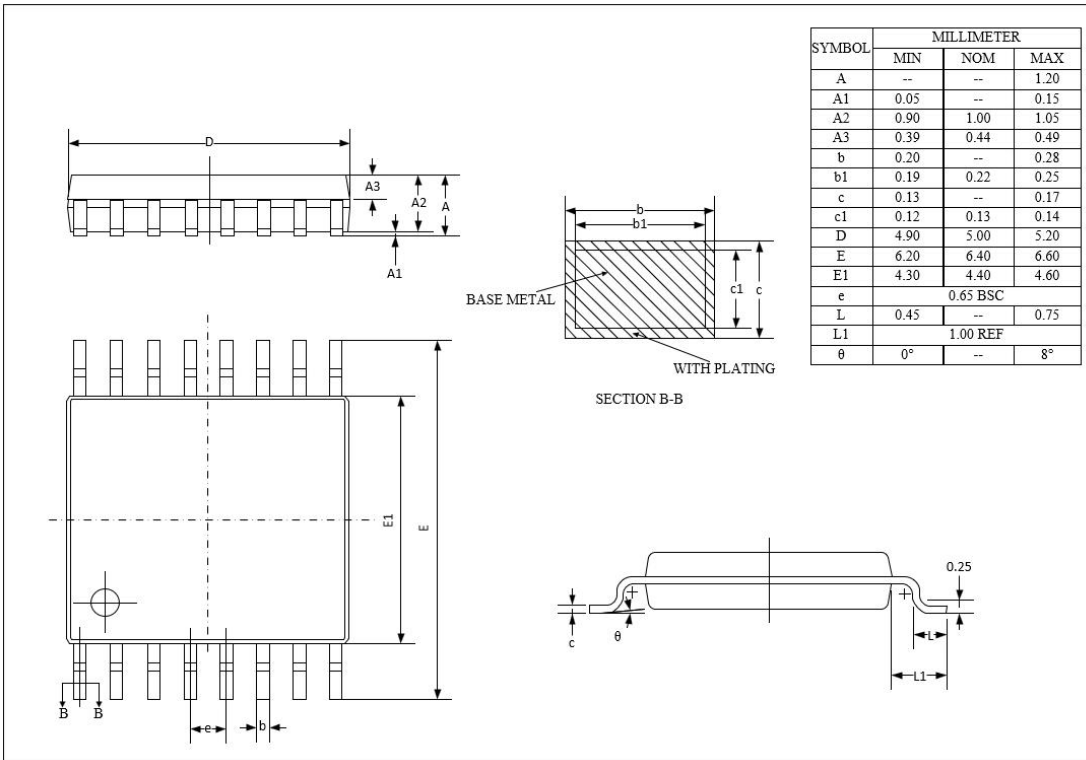

CAUTION: These devices are sensitive to electrostatic discharge; follow proper IC Handling Procedures.
 Linearin and designs are registered trademarks of Linearin Technology Corporation.
 © Copyright Linearin Technology Corporation. All Rights Reserved.
 All other trademarks mentioned are the property of their respective owners.

Important Notice

Linearin is a global fabless semiconductor company specializing in advanced high-performance high-quality analog/mixed-signal IC products and sensor solutions. The company is devoted to the innovation of high performance, analog-intensive sensor front-end products and modular sensor solutions, applied in multi-market of medical & wearable devices, smart home, sensing of IoT, intelligent industrial & smart factory (industry 4.0), and automotives. Linearin's product families include widely-used standard catalog products, solution-based application specific standard products (ASSPs) and sensor modules that help customers achieve faster time-to-market products. Go to <http://www.linearin.com> for a complete list of Linearin product families.

For additional product information, or full datasheet, please contact with the Linearin's Sales Department or Representatives.